



## CONDENSING COMBI-BOILERS

# Installation Manual

Model

! CCOCB80155A CCOCB100180A  
! CCOCB120199A CCOCB140199A

Keep this manual near this boiler for future reference  
whenever maintenance or service is required.



### For Your Safety

**WARNING: If the information in these instructions is not followed exactly, a fire or explosion may result causing property damage, personal injury, or death.**

- Do not store or use gasoline or other flammable vapors and liquids in the vicinity of this or any other appliance.
- WHAT TO DO IF YOU SMELL GAS
  - Do not try to light any appliance.
  - Do not touch any electrical switch; do not use any phone in your building.
  - Immediately call your gas supplier from a neighbor's phone. Follow the gas supplier's instructions.
  - If you cannot reach your gas supplier, call the fire department.

### WARNING

Improper installation, adjustment, alteration, service or maintenance can cause property damage, personal injury (exposure to hazardous materials)\* or loss of life. Refer to the user's information manual provided with this boiler. Installation and service must be performed by a qualified installer, service agency or the gas supplier (who must read and follow the supplied instructions before installing, servicing, or removing this boiler. This boiler contains materials that have been identified as carcinogenic, or possibly carcinogenic, to humans).

This boiler must be installed in accordance with local codes. In the absence of local codes, it must be installed in compliance with The Federal Manufactured Home Construction and Safety Standard Title 24 CFR, part 3280 or CAN/CSA Z240 MH series, mobile home. In the absence of such standard, The Standard for mobile Homes (ANSI/NFPA No. 601B-1977).

The installation must conform with local codes or, in the absence of local codes, the National Fuel Gas Code, ANSI Z223.1/NFPA 54 and/or CAN/CSA B149.1, Natural Gas and Propane Installation Code.

# Safety Information

The following safety symbols are used in this manual for user's safety. Read this manual carefully and follow all instructions to avoid property damage, fire, explosion, personal injury, or death.



## Danger

Indicates an imminently hazardous situation which, if not avoided, will result in severe injury or death.



## Warning

Indicates a potentially hazardous situation which, if not avoided, will result in injury or death.



## Caution

Indicates a potentially hazardous situation which, if not avoided, could result in property damage.



## Danger

### If you smell gas:

- Do not try to light any appliance.
- Do not touch any electrical switches or use landline phones.
- From a neighbor's phone, call your gas provider and follow their instructions.
- If you cannot reach your gas provider, call the fire department.

### Do not use or store flammable products, such as gasoline, solvents, or adhesives in the same room or area as the boiler.

- Vapors from flammable liquids can explode and/or catch fire causing death or severe burns.
- Keep flammable products far away from the boiler and store them in approved containers. Keep the containers tightly closed and out of the reach of children.
- The boiler has a main burner flame that can come on at any time and will ignite flammable vapors.
- Vapors cannot be seen and are heavier than air. They can travel long distances along the ground and can be carried from other rooms to the boiler's main burner flame by air current.

### Avoid using hot water over 125°F.

- Water temperature over 125°F can cause severe burns or death from scalding.
- If it is necessary to set the water temperature above 125°F (52°C), consider installing a thermostatically-controlled mixing valve. Contact a licensed plumber or your local plumbing authority for more information.
- Children, the disabled and the elderly are at highest risk of being scalded.
- Test water before bathing or showering.

Temperature	Time to Produce Serious Burn	Temperature	Time to Produce Serious Burn
120 °F (48 °C)	More than 5 minutes	140 °F (60 °C)	Less than 5 seconds
125 °F (51 °C)	1.5 to 2 minutes	145 °F (62 °C)	Less than 3 seconds
130 °F (54 °C)	Approx. 30 seconds	150 °F (65 °C)	Approx. 1.5 seconds
135 °F (57 °C)	Approx. 10 seconds	155 °F (68 °C)	Approx. 1 second



## Warning

- **Do not store combustibles, such as papers or laundry, near the boiler or venting system.**  
Failure to do so may result in fire or explosion.
- **Do not store or use gasoline or other flammable liquids near this boiler.**  
Failure to do so may result in fire or explosion.
- **Do not store or use compressed gases, such as hair sprays or spray paints, near the boiler or venting system, including the vent termination.**  
Failure to do so may result in fire or explosion.
- **Do not remove the front cover unless the power to the boiler is turned off or disconnected.**  
Failure to do so may result in electric shock.
- **Do not touch the internal components of the boiler or the power cord with wet hands.**  
Failure to do so may result in electric shock.
- **Do not operate the boiler with the front cover opened.**  
Failure to do so may result in fire or carbon monoxide (CO) poisoning, which may result in property damage, personal injury, or death.
- **Do not operate the boiler without proper venting.**  
Failure to do so may result in fire or carbon monoxide (CO) poisoning, which may result in property damage, personal injury, or death.
- **Shut off the gas supply if the boiler is damaged.**  
Have your installer or plumber show you the location of the gas shut off valve and demonstrate how to close the valve. If the boiler is damaged as a result of overheating, fire, flood, or any other reason, close the manual shut off valve and do not operate the boiler again until it has been inspected by a qualified technician.
- **Should overheating occur or the gas supply fails to shut off, do not turn off or disconnect the electrical supply to the pump. Instead, shut off the gas supply at a location external to the application.**
- **Do not use this boiler if any part has been under water. Immediately call a qualified service technician to inspect the boiler and to replace any part of the control system and any gas control which has been under water.**



## Caution

- **Do not use the boiler for anything other than its intended purpose, as described in this manual.**  
Failure to do so may result in property damage, personal injury, or death.
- **Do not turn on the boiler unless the water and gas supplies are fully opened.**  
Failure to do so may damage the boiler.
- **Do not use unapproved replacement or accessory parts.**  
Failure to do so may result in improper or dangerous operation and will void the manufacturer's warranty.
- **When servicing the controls, label all wires prior to disconnecting them.**  
Failure to do so may result in wiring errors.
- **Do not place anything in or around the vent terminals that could obstruct the air flow in or out of the boiler.**  
Failure to do so may result in fire or carbon monoxide (CO) poisoning, which may result in property damage, personal injury, or death.
- **Do not attempt to repair or replace any part of the boiler, unless it is specifically recommended in this manual.**  
For all other service, contact an authorized technician or licensed professional. Improper adjustments, alterations, service, or maintenance may lead to property damage, personal injury, or death and will void your warranty.
- **Do not operate the boiler if you suspect something might be wrong with it.**  
Doing so may result in product damage or personal injury.
- **Do not allow children to operate or have access to the boiler.**  
Doing so may result in product damage or personal injury.
- **Do not use this appliance if any part has been immersed in water.**  
Immediately call a qualified service technician to inspect the appliance and replace any part of the control system and/or any gas control which has been immersed in water.
- **This boiler has been approved for use in the USA and Canada only.**  
Using the boiler in any other country will void the manufacturer's warranty.

# Important Note for the State of Massachusetts

---

## NOTICE BEFORE INSTALLATION

This appliance must be installed by a licensed plumber or gas fitter in accordance with the Massachusetts Plumbing and Fuel Gas Code 248 CMR Sections 4.00 and 5.00.

IMPORTANT: In the State of Massachusetts (248 CMR 4.00 & 5.00)

For all side wall horizontally vented gas fueled equipment installed in every dwelling, building or structure used in whole or in part for residential purposes, including those owned or operated by the Commonwealth and where the side wall exhaust vent termination is less than seven (7) feet above finished grade in the area of the venting, including but not limited to decks and porches, the following requirements shall be satisfied.

1. **INSTALLATION OF CARBON MONOXIDE DETECTORS.** At the time of installation of the side wall horizontal vented gas fueled equipment, the installing plumber or gasfitter shall observe that a hard wired carbon monoxide detector with an alarm and battery back-up is installed on the floor level where the gas equipment is to be installed. In addition, the installing plumber or gasfitter shall observe that a battery operated or hard wired carbon monoxide detector with an alarm is installed on each additional level of the dwelling, building or structure served by the side wall horizontal vented gas fueled equipment. It shall be the responsibility of the property owner to secure the services of qualified licensed professionals for the installation of hard wired carbon monoxide detectors
  - a. In the event that the side wall horizontally vented gas fueled equipment is installed in a crawl space or an attic, the hard wired carbon monoxide detector with alarm and battery back-up may be installed on the next adjacent floor level.
  - b. In the event that the requirements of this subdivision cannot be met at the time of completion of installation, the owner shall have a period of thirty (30) days to comply with the above requirements; provided, however, that during said thirty (30) day period, a battery operated carbon monoxide detector with an alarm shall be installed.
2. **APPROVED CARBON MONOXIDE DETECTORS.** Each carbon monoxide detector as required in accordance with the above provisions shall comply with NFPA 720 and be ANSI/UL 2034 listed and IAS certified.
3. **SIGNAGE.** A metal or plastic identification plate shall be permanently mounted to the exterior of the building at a minimum height of eight (8) feet above grade directly in line with the exhaust vent terminal for the horizontally vented gas fueled heating appliance or equipment. The sign shall read, in print size no less than one-half (1/2) inch in size, "GAS VENT DIRECTLY BELOW. KEEP CLEAR OF ALL OBSTRUCTIONS".
4. **INSPECTION.** The state or local gas inspector of the side wall horizontally vented gas fueled equipment shall not approve the installation unless, upon inspection, the inspector observes carbon monoxide detectors and signage installed in accordance with the provisions of 248 CMR 5.08(2)(a)1 through 4.



# Table of Contents

---

**Safety Information ..... 2**

**Important Note for the State of  
Massachusetts ..... 4**

**General Information..... 6**

Included Items ..... 6  
Optional Accessories..... 6  
Specifications..... 7  
Rating Plate ..... 8  
Dimensions..... 9  
Components ..... 10

**Installing the Boiler ..... 12**

Installer Qualifications..... 12  
Compliance Requirements ..... 12  
Location ..... 12

**Installing the System Piping ..... 15**

Installing a Space Heating System..... 15  
Installing a Domestic Hot Water(DHW) System ... 17  
Connection the Condensate Drain ..... 20  
System Filling..... 21  
Test the Water System ..... 22  
Example of System Applications ..... 22

**Connecting the Gas Supply ..... 25**

Gas Pipe Sizing Tables..... 25  
Gas Piping ..... 26  
Inlet Gas Pressure ..... 27

**Installing a Vent ..... 29**

Vent Type..... 29  
Vent Pipe Materials ..... 33  
Vent Length..... 33  
Connecting the Vent Clip ..... 34  
Vent Termination ..... 34

**Setting the DIP Switches ..... 37**

**Connecting the Power Supply ..... 38**

**Installation Checklist..... 39**

**Operating the Boiler..... 42**

Turning the Boiler On or Off ..... 42  
Checking the ignition system ..... 42  
Setting the Space Heating Temperature ..... 43  
Setting the DHW(Domestic Hot Water)  
Temperature..... 43  
Viewing Basic Information ..... 44  
Setting the Heat Load for The Outdoor Reset  
Control Mode..... 47

**Appendix..... 49**

Gas Conversion ..... 49

**Wiring Diagram..... 53**

**Ladder diagram ..... 54**

**Component Assembly Diagrams and  
Parts Lists ..... 55**

Case Parts (Combi Boiler)..... 55  
Flue Parts (Combi Boiler)..... 57  
Water Parts (Combi Boiler)..... 59

**Normal operating squnce ..... 61**

**Outdoor Temperature Sensor  
Installation ..... 63**

Outdoor Temperature Sensor (Optional)..... 63  
Outdoor Reset Control (Available with Optional  
Outdoor Temperature Sensor)..... 63

# General Information

## Included Items

The following items are included with the boiler. Check each of the following items before installation.

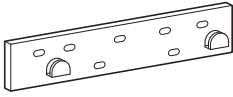

Wall mounting bracket

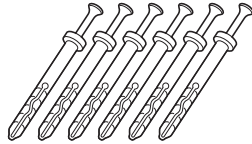

Tapping screws & anchors



Installation and User manual



Quick installation manual

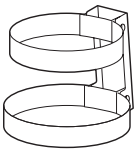

Vent clip

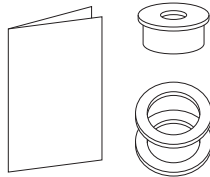

Gas conversion kit

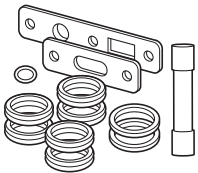

Spare parts

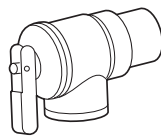

M335-M2(Watts)  
Pressure Relief Valve

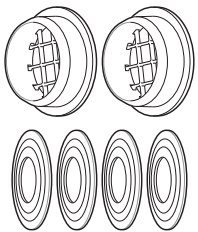

2" Vent termination cap & Wall flange

## Optional Accessories

The following optional accessories are not included with the boiler, but may be necessary for the installation. Check the need for any of the following optional accessories before installation.

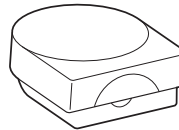

QAC 2030(Siemens)

Outdoor temperature sensor

### Notice

If there is a missing item, please contact Technical Support at 877-241-1224.

## Specifications

The following table shows the specifications for the boiler. Additional specifications about water, gas, electric, and air supplies (venting) appear in each installation section.

MODEL		CCOCB80155A	CCOCB100180A	CCOCB120199A	CCOCB140199A
Heat Capacity (Input)	Space Heating	19,900–80,000 BTU/H	19,900–100,000 BTU/H	19,900–120,000 BTU/H	19,900–140,000 BTU/H
	Domestic Hot Water	19,900–155,000 BTU/H	19,900–180,000 BTU/H	19,900–199,000 BTU/H	19,900–199,000 BTU/H
Flow Rate (DHW)	45°F (25°C) Temp Rise	6.0GPM(23LPM)	6.9GPM(26LPM)	7.7GPM(29LPM)	7.7GPM(29LPM)
	67°F (37°C) Temp Rise	4.0GPM(15LPM)	4.7GPM(18LPM)	5.2GPM(20LPM)	5.2GPM(20LPM)
AFUE	Natural Gas (propane)	95.0%(95.0%)	95.0%(95.0%)	95.0%(95.0%)	95.0%(95.0%)
Dimensions (W x D x H)		18.1" x 27.6" x 11.6" (460 mm x 700 mm x 295 mm)			
Installation Type		Indoor wall-hung			
Venting Type		Forced draft direct vent			
Ignition		Electronic ignition			
Water Pressure(Hydronic/DHW)		12~30psi/15~150 psi			
Supply Pressure	Natural Gas	3.5" – 10.5" WC			
	Propane	8" – 13" WC			
Minimum Flow Rate (DHW)		0.5GPM(2.0LPM)			
Temperature Range	Space Heating	82°F – 180°F(27°C – 82°C)			
	DHW	86°F – 140°F(31°C – 60°C)			
Connection Sizes	Space heating Supply/Return	1" NPT			
	Cold water Inlet	3/4" NPT			
	Hot Water Outlet	3/4" NPT			
	Gas Inlet	3/4" NPT			
Power Supply	Main Supply	120V AC, 60 Hz / use less than 5 AMP			
Materials	Primary Heat Exchanger	Stainless steel			
	Secondary Heat Exchanger				
Venting	Exhaust/Intake		2" or 3" PVC, CPVC, Polypropylene 2" or 3" Special gas vent type BH (Class II, A/B/C)		
	Length	2"	60ft(18.3m)		
		3"	150ft(45.7m)		
	Vent Clearances		0" to combustibles		
Safety Devices		Flame rod, APS, Over heat preventer, Low water cut off switch Exhaust temperature high limit sensor, Power surge fuse			

# Rating Plate



The gas type and electricity voltage must match the rating plate. Using a different gas type and electricity voltage will cause the boiler to malfunction.

Before the installation, check the rating plate located on the side of the boiler to ensure that the boiler matches the gas type, gas pressure, water pressure, and electrical supply available in the installation location. If the boiler does not match each of these ratings, do not install the boiler. If the gas conversion is required, the included gas conversion kit must be used.

### Rating Plate, \*Plaque Signalétique

Combination Boiler and Space Heater / Combiné Chaudière et Chauffe-Espace  
**Custom Comfort**  
 6 Stora Street, Concord, NH 03301  
 Tel : 877-241-1224

For either direct vent installation or for installation using indoor combustion air.  
 Pour une installation à évacuation directe ou pour une installation utilisant de l'air de combustion à l'intérieur.  
 For installation on noncombustible floors only. / Pour l'installation sur des sols incombustibles uniquement. M/C No. 271266

Model No * Numéro de modèle	CCOCB80155A	Type of Gas - Type de gaz	Natural Gas
Max. Input Rating (Space Heating) * Max. Entrée Note (espace de chauffage)	80,000 Btu/h	Min Input Rating * Min. Note d'entrée	19,900 Btu/h
Max. Input Rating (Hot Water) * Max. Entrée Note (eau chaude)	155,000 Btu/h	Heating Capacity * Capacité de chauffage	74,500 Btu/h
Category of boiler * Catégorie de chaudière	Category IV	Electrical Rating * Régime nominal électrique	AC 120 Volts 60 Hz Use less than 5 Amp
Inlet Gas Pressure * Pression de gaz d'entrée	3.5-10.5 Inch W.C.	Manifold Pressure. * Pression d'admission	-0.01-0.28 Inch W.C.
Water temperature limit * limite de température de l'eau	210°F	Minimum relief valve capacity * Capacité minimum soupape	189 lbs/hr

\* Edition of the standard : CSA/ANSI Z21.13 22 CSA 4.9.22

#### INSTALLATION CLEARANCES (DÉGAGEMENTS D'INSTALLATION)

Indoor Installation (Installation Intérieure)

Clearance (dégagement)	Indoor Installation (Installation intérieure)
Top of boiler (Haut de la chaudière)	Min 12 inches (305 mm)
Back of boiler (Retour de la chaudière)	Min 0.6 inches (15 mm)
Front of boiler (Façade de la chaudière)	Min 6 inches (152 mm) Clearance for servicing is 24 in. (610mm) in front of boiler
Side of boiler (Côté de la chaudière)	Min 3 inches (76 mm)
Bottom of boiler (Bas de la chaudière)	Min 12 inches (305 mm)

Minimum Wall Thickness / Épaisseur de paroi minimale : 4 inches (102 cm)  
 Maximum Wall Thickness / Épaisseur de paroi maximale : 20 inches (51 cm)

The pressure relief valve provided by the manufacturer shall be installed at the time of installation of the boiler in the location specified by the manufacturer.  
 (La soupape de décharge de pression fournie par le Fabricant shall être installée au moment de l'installation de la Chaudière l'emplacement spécifié par le fabricant.)

- For safe operation of the boiler, the relief valve must not be removed or plugged.  
 (Pour un fonctionnement sûr de la chaudière la soupape de décharge ne doit pas être enlevée ou branchée)

- No valve shall be placed of in suitable place where it will cause no damage.  
 (Aucune vanne doit être placé dans endroit approprié où il ne causera pas de dommages)

- Also there shall be no other reducing coupling or other restrictions installed on the discharge line to restrict flow.  
 (Aussi il n'y aura pas d'autre raccord de réduction ou d'autres restrictions installées sur la ligne de décharge pour limiter l'écoulement.)

- See installation Manual Heading "PRESSURE RELIEF VALVES" for installation and maintenance of relief valve discharge line and safety precaution.  
 (Voir Installation Rubrique Manuel "SOUPAPES DE DÉCHARGE" pour l'installation et l'entretien de la ligne d'évacuation de la soupape de décharge et de précaution de sécurité.)

Orifices necessary for Propane conversion are provided.  
 \* Les injecteurs nécessaires à la conversion au Propane sont fournis.

**This boiler must be installed with vent the vent-air intake system as specified and installed in accordance with the manufacturer's installation instructions.**  
 \* Cette chaudière doit être installée de manière à purger le système d'admission d'air-air comme spécifié et installée conformément aux instructions d'installation du fabricant.

**Failure to use the correct gas can cause problems which can result in death, serious injury or property damage.**  
 \* Le fait de ne pas utiliser le bon gaz peut causer des problèmes qui peuvent mener à la mort, causer des blessures graves ou endommager la propriété.

Consult your installation manual for more informatio. / Consultez votre manuel d'installation pour plus d'informatio.

**This appliance is certified for use at altitudes up to 2,000 ft (610 m) in accordance to the latest CAN/CSA 2.17 High Altitude Installation procedures at normal manifold pressure. For installation instructions at altitudes higher than 2,000 ft, please contact Custom Comfort.**  
 \* Cet appareil est certifié pour une utilisation à des altitudes de 0 à 2,000 pieds (610 m) conformément aux toutes les procédures d'installation à haute altitude CAN/CSA 2.17 à une pression normale. Pour les installations à élévations en haude 2,000 pieds, appeler le bureau de Custom Comfort.

**This boiler must be installed in accordance with local codes, if any; if not, follow the National Fuel Gas Code, ANSI Z223.1/NFPA 54, or the Natural Gas and Propane Installation Code, CAN/CSA B149.1, as applicable.**  
 \* Cette chaudière doit être installée conformément aux codes locaux, le cas échéant. Sinon, respecter le code national de gaz combustible, ANSI Z223.1 / NFPA 54, ou le code d'installation de gaz naturel et propane, CAN/CSA B149.1, selon le cas.

**This appliance requires a special venting system. Refer to installation instruction for parts list and method of installation**  
 \* Cet appareil nécessite un système de ventilation spécial. Reportez-vous à l'instruction d'installation pour la liste des pièces et de l'installation de la méthode.

**Do not store or use gasoline or other flammable vapors and liquids in the vicinity of this or any other gas appliances.**  
 \* Ne rangez pas et n'utilisez pas d'autres liquides ou vapeurs inflammables près de cet appareil ou de tout autre appareil électroménager.

**When reinstalling the appliance, check the sealing on the exhaust & air intake vent system.**  
 \* Lors de la réinstallation de l'appareil, vérifiez l'étanchéité du système de ventilation d'échappement et d'admission d'air.

PRODUCT NUMBER \* NUMÉRO DE PRODUIT  
 SERIAL NUMBER \* NUMÉRO DE SÉRIE

Made in KOREA / Fabriqué en Corée

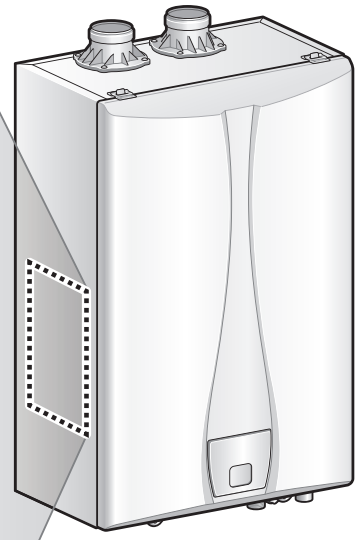

## ■ Dimensions

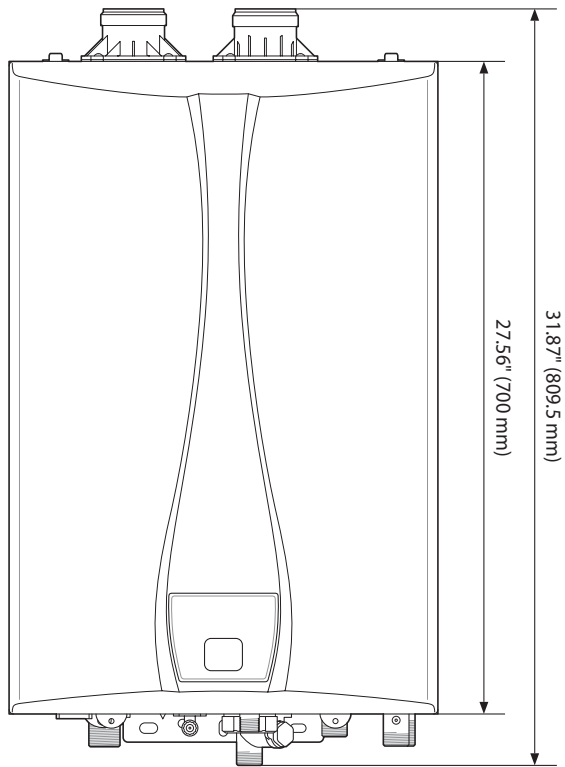

	Description	Diameter
(A)	Space heating Return	1" NPT
(B)	Cold water inlet	3/4" NPT
(C)	Condensate Outlet	1/2" NPT
(D)	Hot water Outlet	3/4" NPT
(E)	Space heating Supply	1" NPT
(F)	Gas Inlet	3/4" NPT
(G)	Exhaust Vent	2"
(H)	Air inlet	2"

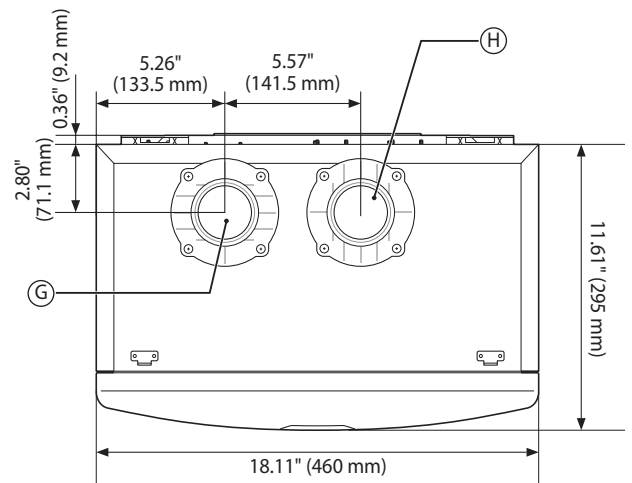
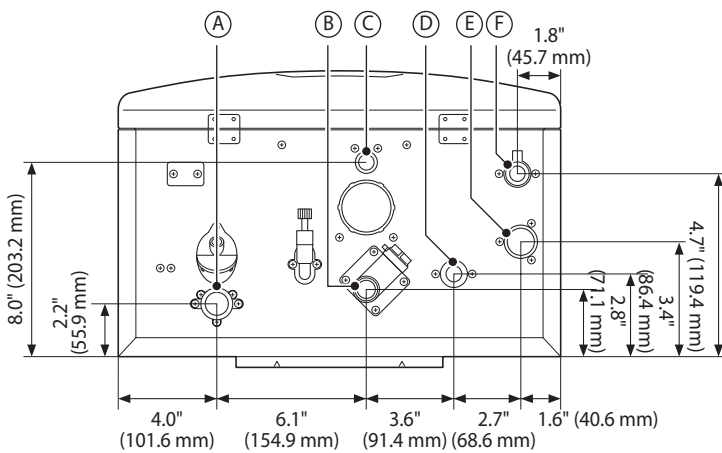

## ■ Components

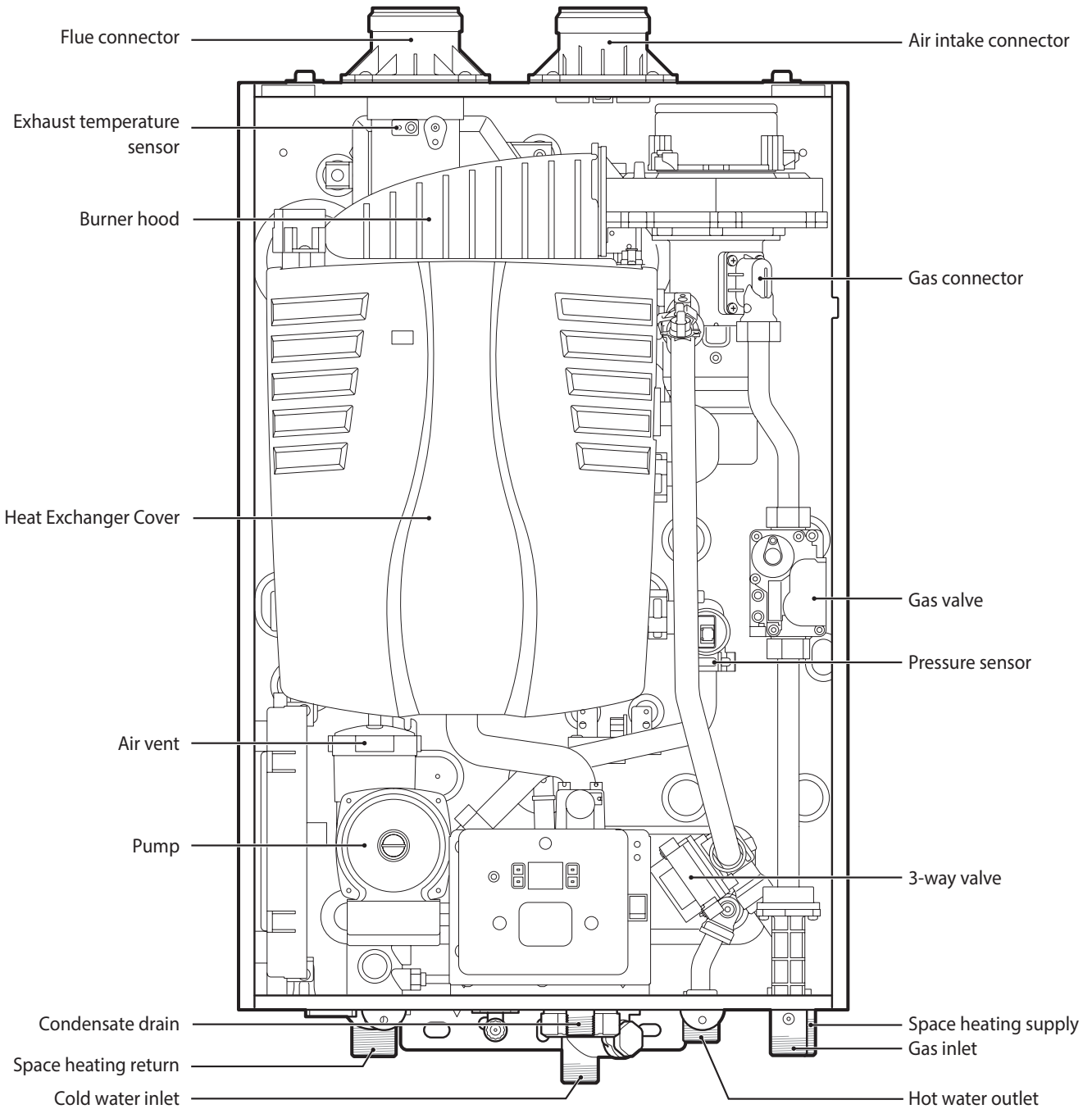

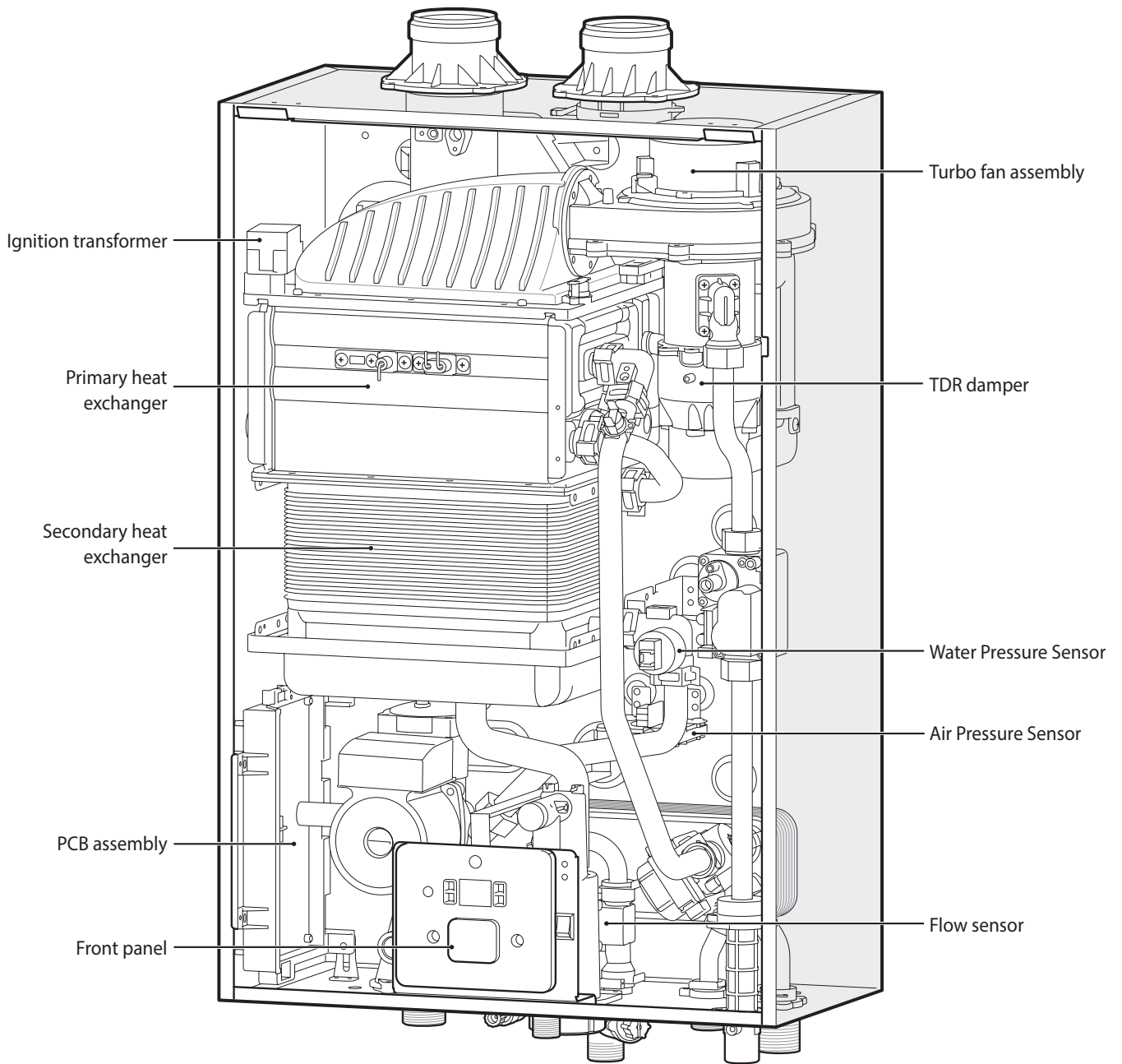

# Installing the Boiler

## ■ Installer Qualifications

A licensed professional must install and inspect the appliance. A licensed professional is a person who is licensed for the following:

- Connecting gas lines, water lines, valves, electricity
- Vent installation through walls and roofs
- Applicable of local, state, and national codes

## ■ Compliance Requirements

- National electrical code.
- National fuel gas code, ANSI Z223.1/NFPA 54 and/or CAN/CSA B149.1, natural gas and propane installation codes.
- Local, state, provincial, and national codes, laws, regulations, and ordinances.
- Standard for Controls and Safety Devices for Automatically Fired Boilers, ANSI/ASME CSD-1, when required.
- For Canada only: B149.1 installation Code, CSA C22.1 Canadian Electricity supply enters the building.

## ■ Location

For installation :

This appliance provides for separation of the combustion system from the indoor atmosphere of the manufactured (mobile) home by an installation method.

This appliance shall be installed only in a space closed from the atmosphere within the manufactured (mobile) home.

The doors or access panels serving the space in which the appliance is located shall communicate only to the outdoors.

in the manufactured homes This appliance shall not be installed in a recreational vehicle.

When considering a location for installation, the installer, must ensure the following:

- Access to utilities
- Humidity and contact with water
- Water quality
- Drainage
- Venting and ventilation
- Proximity to fixtures and appliances
- Clearances
- Clean, debris and chemical-free combustion air
- High elevation Installations

## ● Access to utilities

- Electricity – Close to where the electrical supply enters the building
- Water – Close to where the domestic water supply enters the building
- Gas – Close to where the gas supply enters the building

## ● Humidity and contact with water

Avoid places with excessive humidity. The boiler has electric gas ignition components. If water gets inside the boiler, the ignition system can be damaged. The boiler must be installed in such a way as to ensure that the gas ignition system components are protected from water (dripping, spraying, rain, etc.) during operation and service.

## ● Drainage

A significant amount of condensate is produced during the boiler operation. Install the boiler near a suitable drain and where damage from a possible leak will be minimal. Installing the boiler without a drain will void the warranty. For more information about condensate drainage, refer to "Connection the Condensate Drain" on page 20.

The Boiler must be located in an area where leakage of the unit or connections will not result in damage to the area adjacent to the appliance or to lower floors of the structure. When such locations cannot be found, installation of an adequately-draining drain pan under the boiler is highly recommended. When installing the drain pan, ensure that the installation does not restrict combustion air flow.

## ● Venting and ventilation

Consider venting restrictions caused by windows, doors, air intakes, gas meters, foliage and other buildings, and select a location that requires minimal venting.

When considering an adequate venting and ventilation, ensure the following:

- Maintain a minimum clearance of 4 feet (1.2 meters) from heating and cooling vents.
- Maintain proper clearances from any openings in the building.
- Install the boiler with a minimum clearance of 12 inches (300 mm) above an exterior grade or as required by local codes.
- Install the exhaust vent in an area that is free from obstructions and does not allow the exhaust to accumulate.
- Do not enclose the vent termination.
- Do not install the boiler where moisture from the exhaust may discolor or damage walls.
- Do not install the boiler in bathrooms, bedrooms, or any other occupied rooms that is normally kept closed or that is not adequately ventilated.

For more information about venting, refer to "Installing a Vent" on page 29.



## Clearances

The boiler should be installed in an area that allows for service and maintenance access to utility connections, piping, filters, and traps. Ensure the following clearances are maintained:

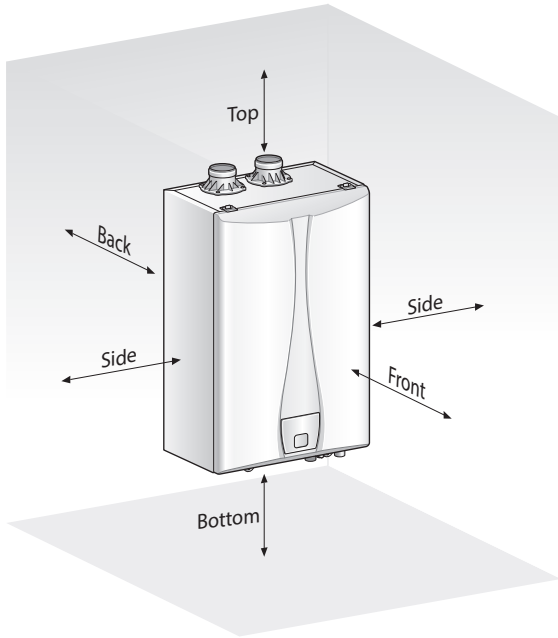

Clearance From	Wall Mounting
Top	12 inches (305 mm) min.
Back	0.6 inches (15 mm) min.
Front	6 inches (152 mm) min.
Sides	3 inches (76 mm) min.
Bottom	12 inches (300 mm) min.



Do not install the boiler on carpeting.

## Clean, debris and chemical-free combustion air

- Do not install the boiler in areas where dust and debris may accumulate or where combustion air can be contaminated.
- Do not install the boiler in areas with greasy fumes or heavy amounts of steam, if necessary, take measures to prevent fumes and steam from entering the boiler.
- Chemicals that are corrosive in nature should not be stored or used near the boiler.

## Position



Caution

Do not mount the boiler to dry wall that has not been reinforced.

The boiler can be mounted to the wall. For easy installation, use the mounting bracket to mount the boiler to standard wall studs. If the strength of the wall is insufficient and or if the framing is non-standard or uneven, reinforce the area before installation. Avoid installation in unstable locations as the boiler will make some operational noises while it is running.



Notice

Consider vent length and surrounding circumstances when mounting the boiler.

## ● Mounting to the wall

To mount the boiler to the wall:

- 1 Check that the wall is level and can support the weight of the boiler.
- 2 Affix the mounting bracket securely to the wall.

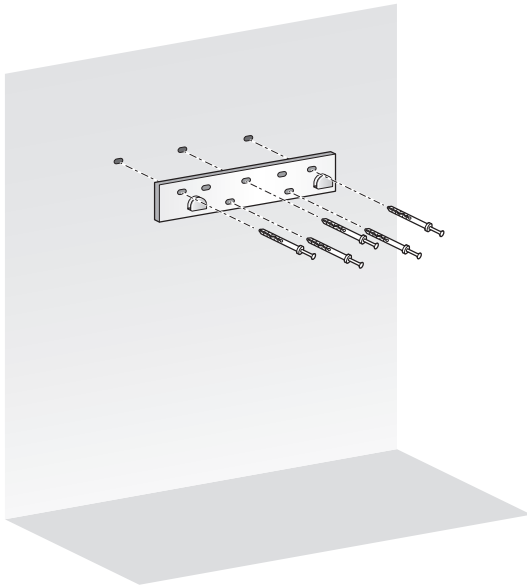

- 3 Align the grooves on the back of the boiler with the tongues on the mounting bracket and hang the boiler from the bracket.

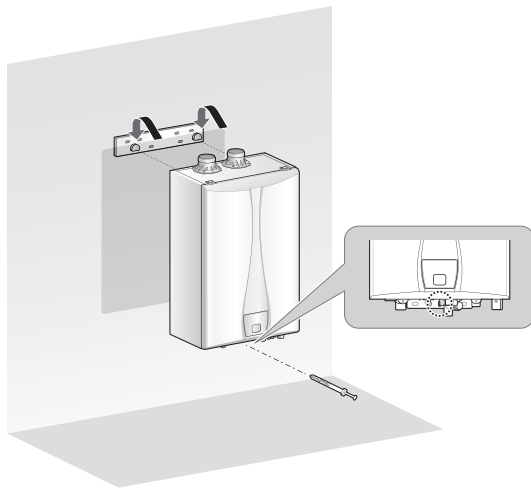

Warning

- **The boiler is heavy.** Always lift the unit with assistance. Be careful not to drop the boiler while lifting or handling it to avoid bodily injury or damage to the unit.
- **Do not** rest the boiler on the bottom end after removing it from the shipping carton. Doing so may result in excessive pressure on protruding pipes and cause product damage. If you must put the boiler down, lay it on its back or put it inside the protective shipping base.

# Installing the System Piping

Before connecting the pipes to the boiler, clean all systems to remove sediment, flux, solder, scale, debris, or other impurities that may be harmful to the boiler system. It is important to maintain the inside of the pipes free of debris, copper dust, sand, and dirt while installing the heating system.

When installing the Custom Comfort boiler and keeping the existing pipes, all pipes including the radiator should be cleaned.



**Warning**

If you fail to remove the above-mentioned contaminants from the heating system, your warranty will be void, the heat exchange will break down faster than normal, and property damage may occur as a result.



**Warning**

For a system requiring freeze protection, use only inhibited propylene glycol, specially formulated for hydronic heating systems; use of other types of antifreeze may be harmful to the system and will void the warranty.

## System Pressure

- Custom Comfort boiler is intended solely for use in a pressurized closed loop heating system operating with 7-30psi water pressure at the boiler outlet. To obtain the minimum system design pressure, comply with the piping diagram in this section.
- The space heating system of Custom Comfort boiler is not approved to operate as an “open system”, and thus cannot be used for direct potable water heating or to process heating of any kind.

## **■ Installing a Space Heating System**

The primary heat exchanger and secondary heat exchanger of Custom comfort boiler are designed optimally to obtain high thermal efficiency. The primary heat exchanger is configured in the finned tube method and the secondary heat exchanger is configured in the plate to plate method, maximizing the heating surface area to achieve high thermal efficiency. In order to allow the heat exchanger to operate effectively over time without trouble, it is important to follow the rules and guidelines mentioned in this section.



**Caution**

If you fail to follow the guidelines provided in this section, your warranty will be void and property damage, fire, serious injury, or death may occur as a result.

## Air Elimination

This boiler can be installed only in a pressurized closed-loop heating system free of air and other impurities.

Install a proper-sized air-purging device at a proper position to eliminate air from the entire heating system.

## **● Guidelines for a Space Heating System**

Read the guidelines below for installing the boiler heating system safely and properly.

### Freeze protection for the space heating system

- Freeze protection products may be used to prevent the space heating system from becoming frozen. A specially manufactured glycol is necessary for preventing a new or existing piping system from becoming frozen. This glycol should include inhibitors not harmful to metallic system components.
- Before using freeze protection products, it is necessary to check if the amount of glycol use in the space heating water is appropriate and if the inhibitor level in such glycol is appropriate. Custom Comfort recommends against exceeding a 35% concentration of glycol.
- If freeze protection products are used, the system should be tested at least once a year.
- When using the freeze protection products, allowance should be made for expansion of the glycol solution.
- Freeze damage is not covered by the warranty.

## Essential Elements in a Space Heating System

### Low Water Cut Off(LWCO) Device

#### Internal LWCO

The Custom Comfort boiler is equipped with a factory-installed, pressure-sensing type low water cutoff (LWCO) device. The minimum operating pressure of this device is 7.1 psig.

Refer to local codes to determine if a LWCO device is required for your system and ensure that the built-in device meets the requirements.

#### External LWCO

Install LWCO if it is required by local code. The following figure shows an example of general LWCO installation.

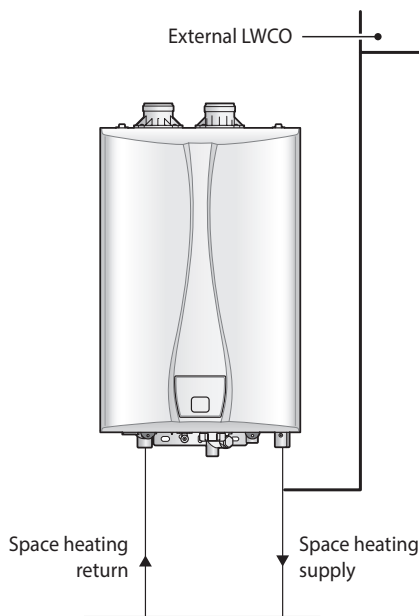

LWCO installed outside should be installed at least 6 inches (150mm) or more away from the end of the heat exchanger.

### Backflow Preventer

When filling the device with water, install a backflow preventer if it is required by local code.

### Expansion Tank

The expansion tank should be installed in the system pipes in order to prevent excessive pressure in the heating pipes.

When installing the expansion tank, follow the guidelines below.

- If the air separator is located on the suction side of the system circulator, connect the air separator to the expansion tank.
- Custom Comfort boiler has a connection (water fill connection) for additional water. Therefore, in most cases, an additional water fill connection is not necessary.

- If an additional water fill connection is necessary for special use, install the water fill connection at the same location as the expansion tank's connection to the system.
- When replacing the expansion tank, refer to the literature of the expansion tank manufacturer for selecting the proper size.
- When installing the diaphragm expansion tank, always install an automatic air vent at the top of the air separator in order to remove residual air in the system.

### Isolation Valves and Unions

- This boiler system requires a full port ball valve. If a full port ball valve is not used, water may flow at a limited flow rate through the boiler.
- It is recommended to use unions for the serviceability of the device.

### Pressure Relief Valve

This boiler comes with an ASME-approved pressure relief valve to install space heating. To complete the installation of the boiler, you must install an approved 3/4", maximum 30 PSI (for space heating).



**Warning**

Improper installation of the pressure relief valve may result in property damage, personal injury, or death. Follow all instructions and guidelines when installing the pressure relief valve. Only a licensed professional should install the valve.



**Caution**

Install the pressure relief valve as close to the boiler as possible. No other valve should be installed between the pressure relief valve and boiler.

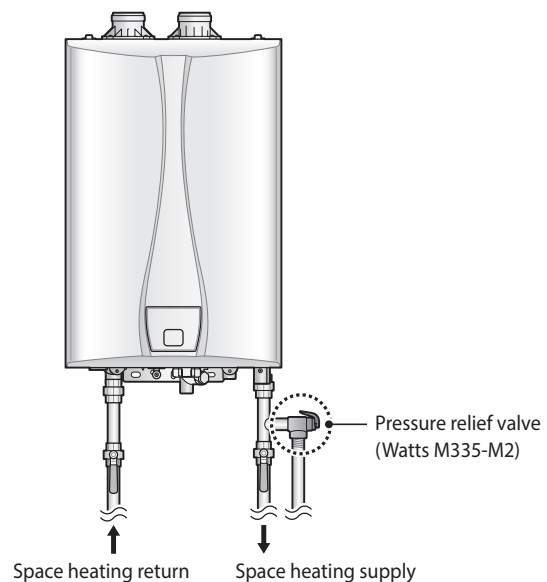

When installing the pressure relief valve, follow the guidelines below.

- The discharge capacity of the valve should be greater than or equal to the maximum pressure rating of the space heating system in the boiler.
- The maximum Btu/h rating of the pressure relief valve should be greater than or equal to the maximum input Btu/h rating of the boiler.
- If the pressure relief valve operates, discharging domestic hot water, domestic hot water may scatter or splash onto other equipment around. Connect the pressure relief valve to the outlet pipe.
- When installing the discharge piping line, do not install a coupling whose internal diameter decreases or has other restrictions.

If the pressure relief valve discharges hot water periodically, thermal expansion may occur due to an expansion tank problem or small expansion tank size. Do not plug the pressure relief valve.

## ● Space Heating Piping

When connecting the space heating system, follow these guidelines.

- Tighten the connection valves carefully in order to avoid damage.
- After installing the boiler, check if the space heating water flows smoothly and if there is a water leak. Inform the boiler owner of the fact that the strainer should be cleaned periodically to maintain the smooth flow of space heating water. (The strainer is located on the side of the space heating return.)

## ■ Installing a Domestic Hot Water(DHW) System

Custom Comfort boiler can supply domestic hot water continuously when the flow rate is detected by the flow switch. This is the most appropriate way to minimize standby losses and improve the combustion efficiency.

### ● Guidelines for a DHW System

Custom Comfort boiler is designed to use space heating and domestic hot water.

This boiler is equipped with the flow switch, and when approximately 0.5GPM or more water flows, the flow switch will sense such water flow. The boiler will then switch to the DHW mode immediately regardless of the space heating system's status.

Read and follow the guidelines stated below for the safety and proper installation of DHW system.

### Scald Hazard

The hotter the water, the higher the risk of burns. If the DHW temperature is set too high, there is a risk of burns from domestic hot water. Make sure to follow the usage guidelines in the user manual.

## **About the DHW Quality**

If the quality of water cannot meet the EPA standard, appropriate boiler maintenance is required. Any damage resulting from bad quality of water voids the warranty. The following table shows the permitted maximum contaminant levels based on the EPA National Secondary Drinking Water Regulations (40 CFR Part 143.3).

<b>Contaminant</b>	<b>Maximum Allowable Level</b>
Total Hardness	200 mg/l (12 grains/gallon)
Aluminum	0.05 – 0.2 mg/l
Chloride	250 mg/l
Copper	1.0 mg/l
Iron	0.3 mg/l
Manganese	0.05 mg/l
pH	6.5 – 8.5
Sulfate	250 mg/l
Total Dissolved Solids (TDS)	500 mg/l
Zinc	5 mg/l

Custom Comfort is not responsible for the blockage of the domestic system due to the accumulation of foreign matters or scaling.

The installer or the user should take appropriate measures in order to avoid any problem related to the quality of water.

## **Freeze Protection**

Custom Comfort recommends insulating the DHW pipes. The pipes can be covered using heat-insulating materials. Freeze damage voids the warranty.

## **● Essential Elements in a DHW System**

### **DHW Heat Exchanger**

The DHW heat exchanger installed on the Custom Comfort boiler is designed to withstand a significant amount of water pressure.

### **Drain and Isolation Valves**

Install drain and isolation valves on the inlet and outlet of the DHW heat exchanger, so it can be flushed free of possible build-up caused by dirt or hard water.

### **DHW Filter**

Custom Comfort boiler has a filter on its cold water inlet nipple. Clean the filter periodically to prevent the interruption of water flow by foreign matters.

If such foreign substances adhere to the flow switch, the boiler may malfunction.

## Pressure Relief Valve for DHW

To complete the installation of the DHW system, you must install the approved  $\frac{3}{4}$ " maximum 150psi pressure relief valve on the hot water outlet.



**Warning**

Improper installation of the pressure relief valve may result in property damage, personal injury, or death. Follow all instructions and guidelines when installing the pressure relief valve. Only a licensed professional should install the valve.

The DHW pressure relief valve is not provided together with the product. However, it is necessary to install such a valve.



**Caution**

Install the pressure relief valve as close to the boiler as possible. No valve should be installed between the pressure relief valve and the boiler.

When installing the pressure relief valve, follow the guidelines below.

- The discharge capacity of the valve should be greater than or equal to the maximum pressure rating of the DHW system in the boiler.
- The maximum Btu/h rating of the pressure relief valve should be greater than or equal to the maximum input Btu/h rating of the boiler.
- If the pressure relief valve operates, discharging domestic hot water, domestic hot water may scatter or splash onto other equipment around. Connect the pressure relief valve to the outlet pipe.
- When installing the discharge piping line, do not install a coupling whose internal diameter decreases or has other restrictions.

If the pressure relief valve discharges hot water periodically, it may be caused by thermal expansion of the closed water system. Contact the water supplier or a local plumbing inspector in order to solve such a problem. Do not plug the pressure relief valve.

## DHW System Piping



**Caution**

In order to meet the requirements of ASME or CRN, an additional high temperature limitation device may be necessary. Refer to the requirements of the local code for whether this device is necessary or not.

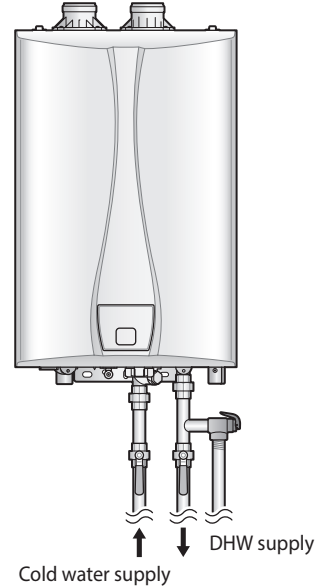

When installing the DHW system, follow the guidelines below.

- Only use permitted pipes, valves and other parts such as a solder for the potable water system.
- Tighten the connection valves carefully in order to avoid damage.
- Custom Comfort recommends the use of unions and manual shut-off valves for the cold water inlet and DHW outlet.
- Keep the hot water piping system as short as possible, to deliver hot water to the fixtures more quickly.
- When installing a mixing valve on the DHW piping, ensure that the cold water pressure does not exceed the hot water pressure.
- To conserve water and energy, insulate the DHW supply and DHW recirculation lines (if applicable). Do not cover the drains or pressure relief valves.
- After installing the boiler, clean the cold water inlet filter. Then, check if domestic water flows properly and check for water leaks. Inform boiler owner that the filter should be cleaned periodically to ensure that domestic hot water flows smoothly.

## Connection the Condensate Drain



### Caution

- All condensate must drain and be disposed of according to local codes.
- Do not cap or plug the integrated condensate line. If prevented from draining, condensate can damage the boiler.
- The condensate line must have a negative slope to drain properly.
- Do not run drain outdoors. Freezing of condensate can cause property damage.
- Do not connect the condensate drain line directly to the rain sewer.
- Do not connect the condensate drain line with an air conditioning evaporator coil drain.
- Use only corrosion resistant materials for the condensate drain lines such as PVC pipe or plastic hose.
- The end of the condensate drain pipe should be open to the atmosphere. The end should not be under water or other substances.

The Custom Comfort boiler creates condensation when it operates. This condensation has an acidic pH of 3-5. Follow all local codes and regulations when disposing of condensate from the boiler. We recommend draining the condensate into a laundry tub, as the alkali in laundry detergent will neutralize the acid in the condensate. However, other suitable waste drain locations may be used according to local codes.

Before connecting the condensate drain, choose one of the following disposal options:

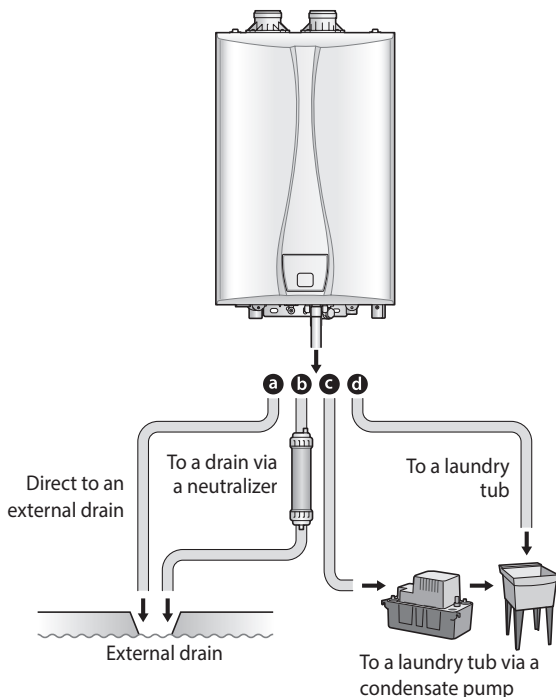

- (a) From the boiler directly into an external drain.  
 (b) From the boiler, through a neutralizing agent, and then into an external drain.

### Notice

- If you choose this option, the neutralizing agent must be replaced periodically. Depletion of the neutralizing agent will vary, based on the usage rate of the boiler. During the first year of operation, the neutralizer should be checked every few months for depletion and replaced as needed.

- (c) From the boiler into a condensate pump, and then into a laundry tub.

### Notice

A pump can be used when there is a long distance between the boiler and the laundry tub or when the bottom of the boiler is lower than the top of the laundry tub.

- (d) From the boiler into a laundry tub.

### Notice

The bottom of the boiler must be higher than the top of the laundry tub to use this option. The condensate line must have a negative slope to drain properly.

To connect the condensate drain:

- 1 Connect a drain line to the boiler.

### Notice

Use only corrosion-resistant material for the drain line, such as PVC or CPVC. Do not reduce the size of this fitting or the drain line to less than 1/2".

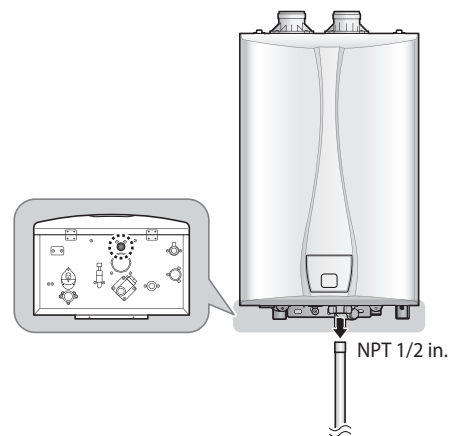

- 2 Place the free end of the drain line into an appropriate drain.

### Notice

- If you are using a condensate pump, ensure that the pump allows for up to 2 GPH of drainage for each boiler in the system.
- If you are not using a condensate pump, ensure that the drain line is pitched downward at a minimum slope of 1/4" per foot.



## ● Filling the Condensate Trap

Before operating the boiler, fill the condensate trap with water through the flue connector. The boiler may be severely damaged unless filled with water prior to operation. Pour more than 0.1 gallon (400 ml) of water into the exhaust duct. Deflate air sufficiently or equip the air vent with an outlet pipe prior to filling the condensate trap with water (there must be no air inside the heat exchanger).



## ■ System Filling

### ● Built-in water filling

Custom Comfort boiler is designed to fill the system with water. Therefore, additional water fill connection is not necessary in most cases. Filling the system with water should be carried out after all space heating pipes and DHW pipes are connected.

The procedure is as follows.

- When you turn the makeup water feeding valve shown in the figure below counterclockwise, the space heating system will be filled with water.
- When filling with water after installing it for the first time, it may operate and stop repeatedly due to the presence of air. Allow sufficient time to remove air from the pipes completely.
- After filling with water completely and removing air completely, close the makeup water feeding valve by turning it clockwise.
- Fill the system with water to a level at which the pressure inside the system does not exceed 30psi.

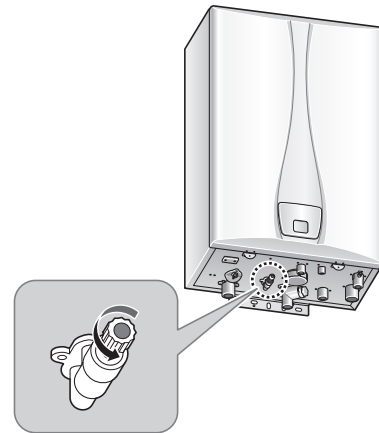

### ● External Water Fill Connection

External water fill connection may be installed on the system piping if it is required for specific applications. See the following figure for an example of external water fill installation on the system piping.

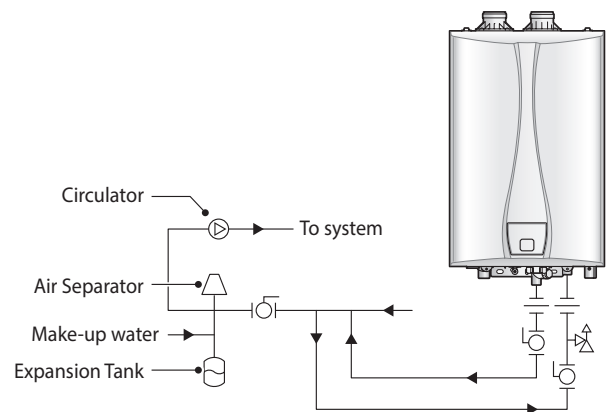

## ■ Test the Water System



### Warning

Ensure that the boiler is full of water before firing the burner. Operating the unit without filling it will damage the boiler. Such damage is not covered by the warranty, and may result in property damage, severe personal injury, or death.

Perform fill test after installing the boiler's water system to make sure that the system has been installed properly. Follow the instructions below to perform a fill test on the water system.

- Fill the boiler with water after checking that the chemical composition of water meets the requirements mentioned in this manual.
- Close the drain valve of the boiler.
- Fill the boiler with water. The correct pressure will vary with each application. The normal pressure of the residential system is 12psi. The operating pressure must never exceed the relief valve pressure setting.
- While filling with water for the first time and carrying out the operation test, check for water leaks from the pipes. If there is a water leak, stop the operation, repair the leak, and continue the operation.

This system may have residual substances that could affect water chemistry. After filling the system with water and completing the water leak test, verify that water PH and chlorine concentrations are within the acceptable range by performing sample testing.



### Caution

Before operating the boiler for the first time, check if the boiler is filled with water. To avoid boiler damage, remove all air from the system.

## ■ Example of System Applications

Refer to the following examples to properly implement a system for space heating, DHW supply, or both. These examples are provided to suggest basic guidelines when you install the boiler system. However, the actual installation may vary depending on the circumstances, local building codes, or state regulations. Check the local building codes and state regulations thoroughly before installation, and comply with them fully.

### ● External Water Fill Connection

Read and follow the guidelines below for system piping of the Custom Comfort boiler.

- System application drawings are intended to explain the system piping concept only
- When installing a mixing valve on the DHW piping, ensure that the cold water pressure does not exceed the hot water pressure.
- For the upstream side of all circulator, use straight pipes with a minimum diameter of ½" (12mm)
- Provide a system expansion tank following the guidelines on page 16
- Installations must comply with all local codes, IN Massachusetts, a vacuum relief valve must be installed in the cold water line per 248 CMR.

### Air Removal

The boiler and system plumbing layout must be configured to promote the removal of air from the water. Air vents and bleeders must be strategically placed throughout the system to aid in purging the air from the system during commissioning of the boiler. The system must also employ the use of a strategically located air removal device, such as an air scoop or micro-bubbler, designed to remove the air from the water as it flows through the system.

Follow the installation instructions included with the air removal device when placing it in the system ; air removal devices generally work better when placed higher in the system. Always locate air removal devices in areas of the system that have a guaranteed positive pressure, e.g., in close proximity to the water fill and expansion tank



### Notice

Custom Comfort boiler has an air vent inside the product in order to purge air in the system.

## Expansion Tank

The size of expansion tank should be decided according to the boiler capacity and the amount of water in the system. It is important to locate the expansion tank, and make-up water fill, on the inlet side of any circulator in the system, as doing so will guarantee the lowest pressure in the system will be at least equal to the tank and make-up water pressure.

Ensure the expansion tank cannot become isolated from the boiler anytime the system is operating. Failure to follow these instructions may lead to discharge from the pressure relief valve, which may result in property damage or injury.

## System Application – Zone System with Zone Valves

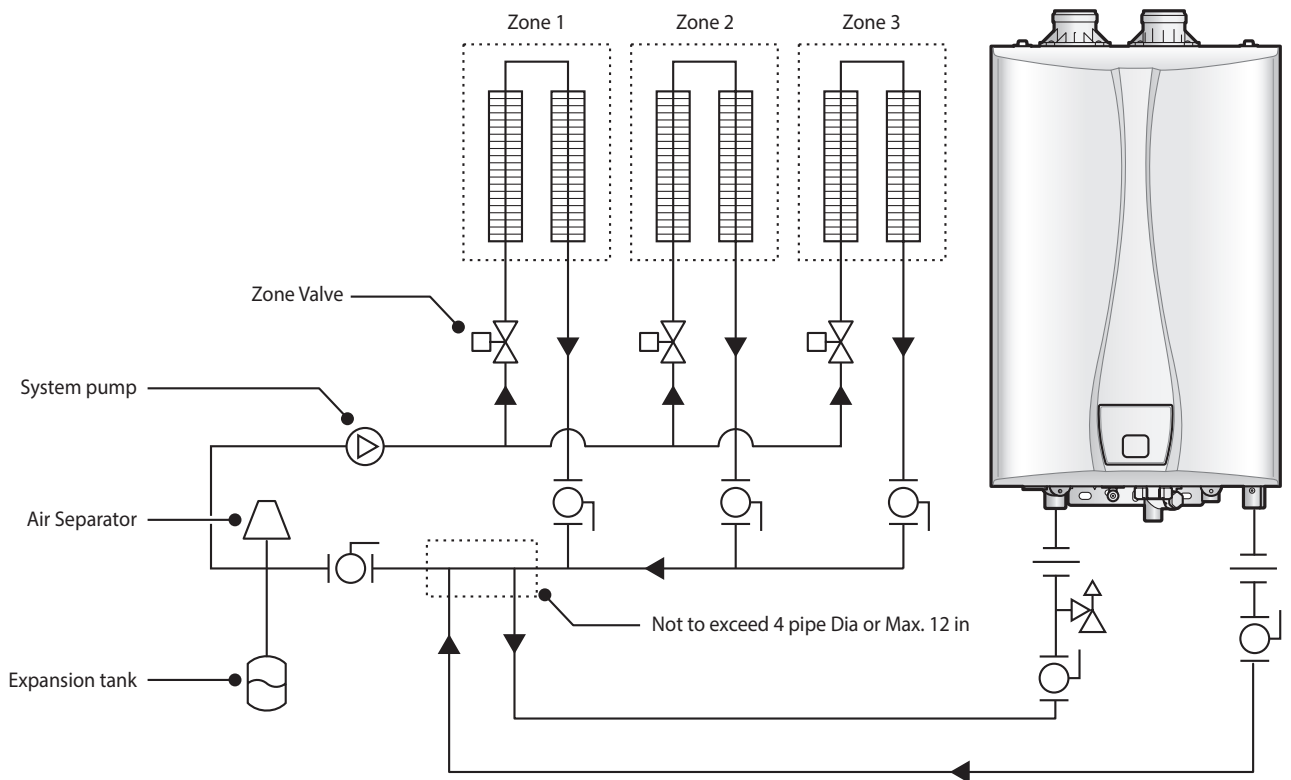

## System Application – Zone System with Circulators

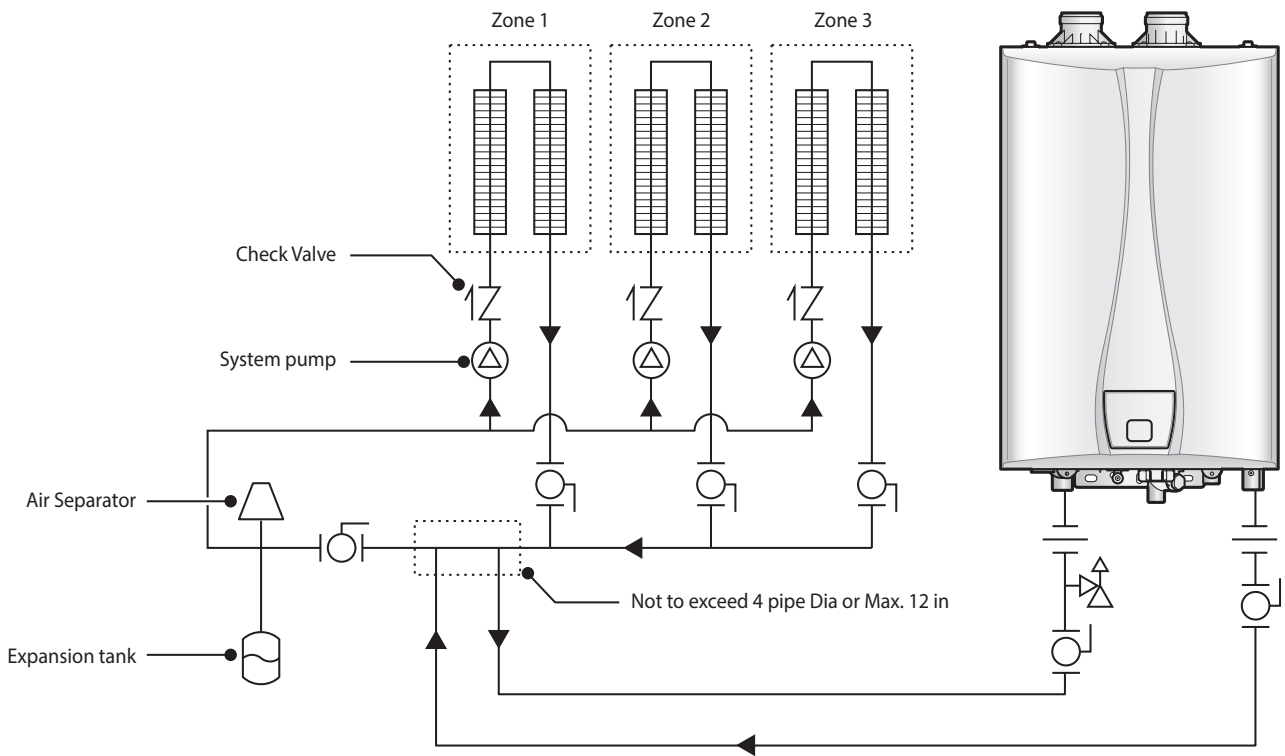

# Connecting the Gas Supply

## Gas Pipe Sizing Tables

Gas pipe sizing is based on the gas type, supplied gas pressure, pressure drop in the system, and gas line type. The tables below are for reference only (when the gas supply is piping straight to the boiler with no connections to any other gas appliances). For gas pipe sizing, refer to the latest National Fuel Gas code, NFPA 54 and consult the gas pipe manufacturer for actual gas pipe capacities.

### Natural gas

Table 1. For less than 6" WC supply pressure.

Maximum Capacity of Natural Gas Based on a 0.60 specific gravity at a 0.5" WC pressure drop.

Pipe Size	kBTU/H of Natural Gas												
Length	10'	20'	30'	40'	50'	60'	70'	80'	90'	100'	125'	150'	200'
3/4"	360	247	199	170	151	137	126	117	110	104	92	83	71
1"	678	466	374	320	284	257	237	220	207	195	173	157	134
1 1/4"	1390	957	768	657	583	528	486	452	424	400	355	322	275
1 1/2"	2090	1430	1150	985	873	791	728	677	635	600	532	482	412
2"	4020	2760	2220	1900	1680	1520	1400	1300	1220	1160	1020	928	794
2 1/2"	6400	4400	3530	3020	2680	2430	2230	2080	1950	1840	1630	1480	1270
3"	11300	7780	6250	5350	4740	4290	3950	3670	3450	3260	2890	2610	2240
4"	23100	15900	12700	10900	9660	8760	8050	7490	7030	6640	5890	5330	4560

Table 2. For 6" WC or greater supply pressure.

Maximum Capacity of Natural Gas Based on a 0.60 specific gravity at a 3.0" WC pressure drop.

Pipe Size	kBTU/H of Natural Gas												
Length	10'	20'	30'	40'	50'	60'	70'	80'	90'	100'	125'	150'	200'
1/2"	454	312	250	214	190	172	158	147	138	131	116	105	90
3/4"	949	652	524	448	397	360	331	308	289	273	242	219	188
1"	1790	1230	986	844	748	678	624	580	544	514	456	413	353
1 1/4"	3670	2520	2030	1730	1540	1390	1280	1190	1120	1060	936	848	726
1 1/2"	5500	3780	3030	2600	2300	2090	1920	1790	1670	1580	1400	1270	1090
2"	10600	7280	5840	5000	4430	4020	3690	3440	3230	3050	2700	2450	2090
2 1/2"	16900	11600	9310	7970	7060	6400	5890	5480	5140	4860	4300	3900	3340
3"	29800	20500	16500	14100	12500	11300	10400	9690	9090	8580	7610	6890	5900
4"	60800	41800	33600	28700	25500	23100	21200	19800	18500	17500	15500	14100	12000

### Liquid propane gas

Maximum Capacity of propane (Propane) Gas Based on 11" WC supply pressure at a 0.5" WC pressure drop.

Pipe Size	kBTU/H of Propane Gas												
Length	10'	20'	30'	40'	50'	60'	80'	100'	125'	150'	175'	200'	250'
1/2"	291	200	160	137	122	110	101	94	89	84	74	67	62
3/4"	608	418	336	287	255	231	212	197	185	175	155	140	129
1"	1150	787	632	541	480	434	400	372	349	330	292	265	243
1 1/4"	2350	1620	1300	1110	985	892	821	763	716	677	600	543	500
1 1/2"	3520	2420	1940	1660	1480	1340	1230	1140	1070	1010	899	814	749
2"	6790	4660	3750	3210	2840	2570	2370	2200	2070	1950	1730	1570	1440

## Gas Piping



**Danger**

- Do not connect to an unregulated or high pressure propane line or to a high pressure commercial natural gas line.
- The boiler must be isolated from the gas supply piping system during any pressure testing of that system at test pressures equal to or more than 0.5 psig.



**Warning**

- Only a licensed professional should connect the gas supplies.
- Before connecting the gas supply, determine the gas type and pressure for the boiler by referring to the rating plate. Using a different gas type will result in abnormal combustion and malfunction of the boiler causing fire or explosion.
- Leak test the appliance and its gas connection before operating the boiler.
- Do not attempt a field conversion without a Custom Comfort conversion kit. Use the Custom Comfort conversion kit to convert from natural gas to propane or vice versa. Failure to do so may result in dangerous operating conditions and will void the warranty.
- A sediment trap must be provided upstream of the gas controls.

In the United States: The installation must conform with local codes or, in the absence of local codes, the National Fuel Gas Code ANSI Z223.1/NFPA 54.

In Canada: The Installation must conform to CAN/CSA B149 INSTALLATION CODES and/or local installation codes.

To ensure a sufficient gas supply, it is recommended that the boiler be the first appliance to be connected to the gas supply line.

To connect the gas supply:

- 1 Determine the gas type and pressure by referring to the rating plate.
- 2 Perform a pressure test on the main gas supply line.
- 3 Purge the gas line of any debris.
- 4 Determine the proper type and size for the gas line. Refer to the gas pipe sizing tables on page 25.
- 5 Install a union.
- 6 Install a manual gas shut off valve on the gas supply line within easy reach of the appliance.



**Warning**

- The manual gas shut off valve is not provided together with the product.
- Improper installation of the manual gas shut-off valve may result in property damage, personal injury or death.
- Only a licensed professional, in accordance with the ANSI Z21.1/CSA 9.1, should install the manual gas shut-off valve.

### 7 Connect the gas supply line.

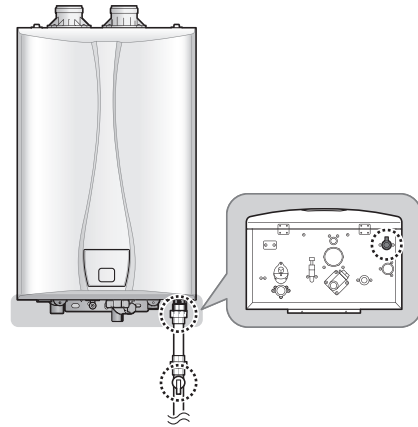

### 8 Check for gas leaks at all joints.

#### Notice

- Tighten the boiler connection valves with care to avoid damage.
- Apply gas leak detection solution to all gas fittings.
- The minimum internal diameter required for any appliance connector is 3/4".
- When using flexible gas lines, ensure that the pipe's inner diameter and connector is sufficient to supply the required BTUs. Also, ensure that the flexible line has no crimps or tight bends in it, as this will restrict gas flow.
- To facilitate any future maintenance or service, the installation of a union on the gas supply line close to the boiler is recommended.

- The following is a Propane gas piping example for the single regulator system

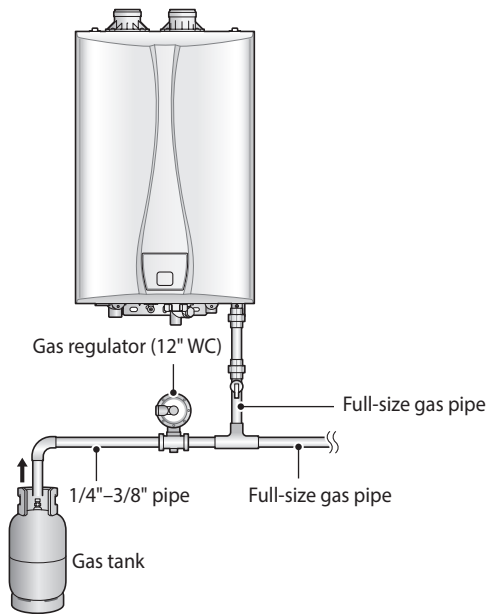

- The following is an Propane gas piping example for the 2-lb. system with multiple regulators.

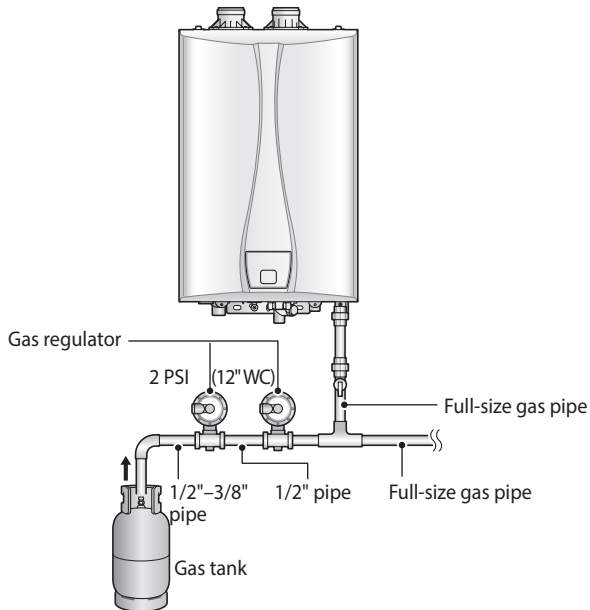

## Inlet Gas Pressure



**Warning**

Inlet gas pressure should be measured by a licensed professional only. The boiler cannot function properly without sufficient inlet gas pressure.

- The boiler must be isolated from the gas supply piping system during any pressure testing of that system at test pressures equal to or more than 0.5 psig. If overpressure has occurred, through improper testing of the gas lines or malfunction of the supply system, the gas valve must be checked for safe operation.
- The inlet gas pressure must be maintained between 3.5" and 10.5" WC for natural gas and between 8" and 13" WC for liquefied propane.

To measure the inlet gas pressure:

- 1 Shut off the manual gas valve on the gas supply line.

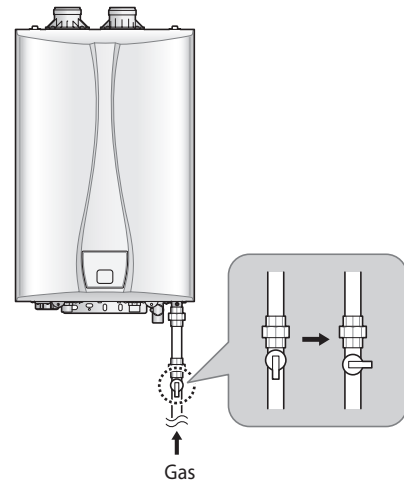

- 2 Open a hot water faucet. The boiler should turn on and the gas in the gas supply line will be purged.
- 3 Leave the faucet on until the boiler shuts down due to a lack of gas supply, and then turn off the hot water faucet.

- 4** Remove the boiler front cover by loosening the 2 Phillips screws securing it to the case.

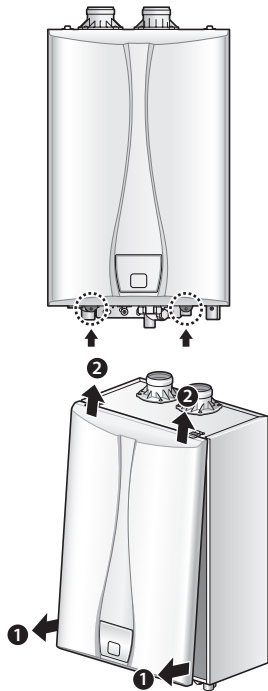

- 5** Loosen the screw indicated in the figure below and connect a manometer to the inlet pressure port. Reset the manometer to zero before use.

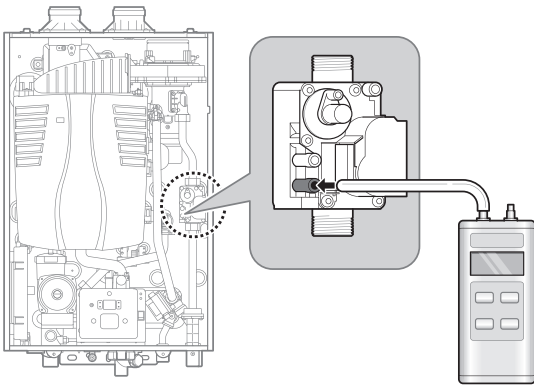

- 6** Re-open the manual gas shut-off valve and check for leaks.
- 7** Open multiple fixtures that have high flow rates, such as bathtub and shower faucets, to ramp up the boiler to its maximum firing rate.

- 8** When the boiler reaches its maximum firing rate, check the inlet gas pressure reading on the manometer. The gas pressure must fall within the ranges specified in "Specifications" on page 7.

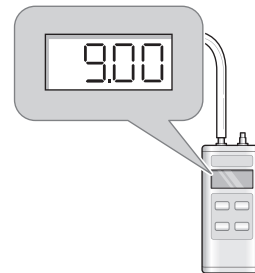

- 9** Tighten the inlet gas pressure screw.
- 10** Replace the front cover and tighten the 2 Phillips screws to secure it to the case.



# Installing a Vent



## Warning

Improper venting of the boiler can result in excessive levels of carbon monoxide, which can lead to severe personal injury or death. This boiler must be vented in accordance with the "Venting of Equipment" section of the latest edition of the ANSI Z223.1/NFPA 54 Natural Fuel Gas Code in the USA and/or the "Venting systems and air supply for boilers" section of the latest version of Clause 8.2, 8.3 or 8.4 of Natural Gas and Propane Installation Code, CAN/CSA B149.1 in Canada, as well as all applicable local building codes and regulations. Follow all instructions and guidelines when venting the boiler. Venting should be performed only by a licensed professional.

The boiler must be properly vented to ensure a constant supply of clean intake air and to ensure that exhaust air is properly removed from living areas. When venting the boiler, follow these guidelines:

- Do not install the boiler in areas with contaminated air (containing a high level of dust, sawdust, sand, four aerosols, or any other such airborne contaminants), as contaminants can cause operational problems. The warranty does not cover damage caused by contaminants in the installation area. If you must install the boiler in an area with contaminated air, use direct venting to supply air from outside the building. We recommend regular filter cleaning and maintenance in these areas.
- For best results, keep the venting system as short and straight as possible.
- Locate the boiler as close as possible to the vent termination.
- Do not connect the boiler vent to a vent for any other gas boiler or vent stack.
- For horizontal runs, slope the horizontal section upward toward the vent termination at a rate of 1/4" per foot (2% slope).
- Create an airtight seal at each joint in the exhaust and intake air pipes from the boiler collar to the vent termination.
- To avoid moisture and frost build-up and to maintain clearances to openings on adjacent homes, 45° elbows, 90° elbows, or tees may be attached to the end of the termination vent pipe to direct the exhaust fumes away from buildings, as long as the restrictions on total allowable vent lengths, maximum number of elbows, and distances to air intake are observed.
- Do not store hazardous or flammable substances near the vent termination.
- If this boiler is to be installed in an area where snow is known to accumulate, protect the vent termination from blockage.
- Ensure that the vent termination is at least 12" (305mm) above ground, or as required by local codes.
- Support the vent pipe with hangers at regular intervals or as required by local codes.
- Exhaust and intake air pipes must be supported at least every 4 feet (1.2m).
- The vent for this appliance shall not terminate over public walkways; or near soft vents or crawl space vents or where condensate or vapor could create a nuisance or hazard or cause property damage; or where condensate or vapor could cause damage or could be detrimental to the operation of regulators, relief valves, or other equipment.

## Vent Type

All boilers are prepared at the factory to be direct vent (sealed combustion) boilers that draw all of their required combustion required combustion air directly from outside the building. Custom Comfort recommends direct air vent installations whenever possible to avoid back drafting cold air through the boiler. Custom Comfort recommends direct air vent installations when installing the boiler in your attic to get fresh air into the boiler. If you cannot use a direct vent, ensure that an ample supply of make-up air is available in the installation location. Custom Comfort also recommends installing a new vent system with this appliance. If reusing an existing vent system, thoroughly inspect it for punctures, cracks, or blockages prior to connecting it to the boiler. When using non-direct venting, must provide two openings as specified in the table on page 28.

## Direct

The boiler uses 2" or 3" diameter exhaust and 2" or 3" diameter intake air ducts. To ensure the draw of air directly from and exhaust of air directly to the outside of the building, create an airtight seal from the boiler collar to the vent termination.

Intake materials can be made of ABS, PVC, CPVC, PP, galvanized steel, corrugated aluminum or any other similar materials. If you use a corrugated material, ensure that there is not inadvertent crimping of, or damage to, the intake air pipe.

When using direct venting, maintain the following venting clearances, as required by ANSI Z21.10.3 and the National Fuel Gas Code, ANSI Z223.1/NFPA 54, and CAN/CSA B149.1 Natural Gas and Propane Installation Code.

To use direct venting for the boiler:

- Install the 2" vent directly. Ensure the vent is properly seated.
- To install the 3" vent, reducer (3" to 2") must be used.
- Install the reducer (3" to 2") vertically. If installed horizontally, water may stagnate.

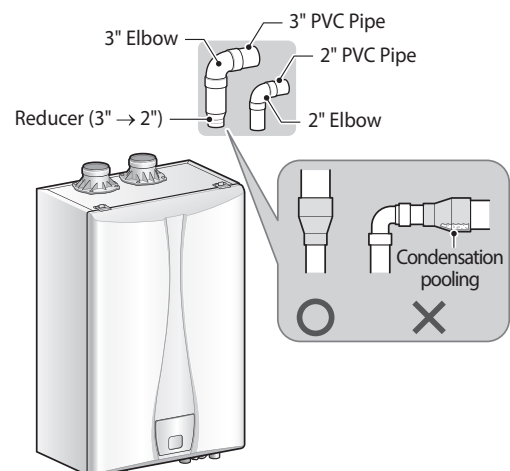

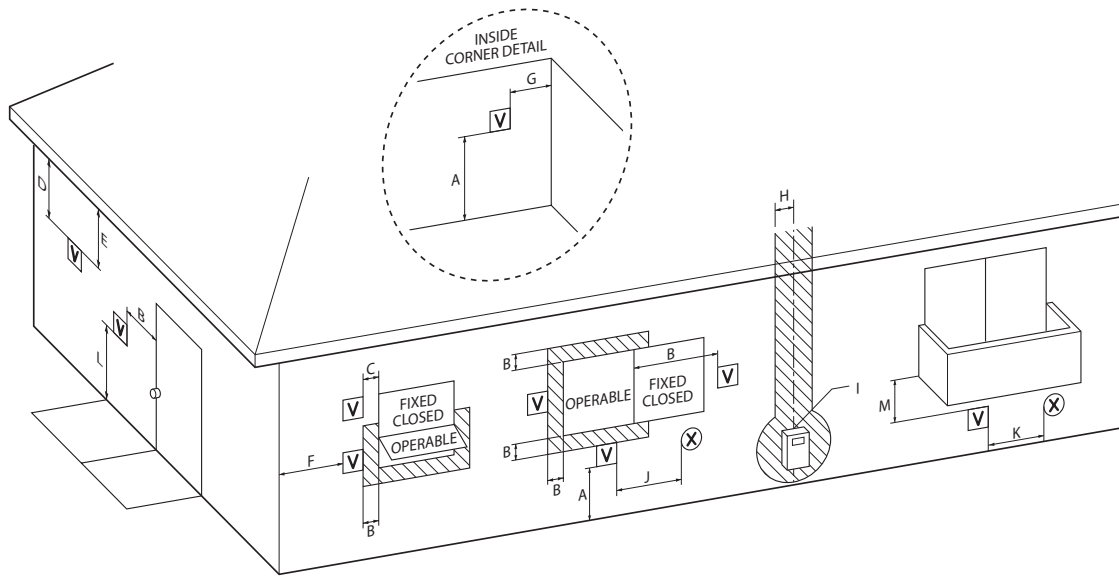

**V** VENT TERMINAL

**X** AIR SUPPLY INLET

**▨** AREA WHERE TERMINAL IS NOT PERMITTED

		Canadian Direct Vent Installations <sup>1)</sup>	U.S. Direct Vent Installation <sup>2)</sup>
A	Clearance above grade, veranda, porch, deck or balcony	12 in. (30 cm)	12 in. (30 cm)
B	Clearance to window or door that may be opened	36 in. (91 cm)	12 in. (30 cm)
C	Clearance to permanently closed window	*	*
D	Vertical clearance to ventilated soft located above the vent termination within a horizontal distance of 2 feet (61 cm) from the center line of the termination	*	*
E	Clearance to unventilated soft	*	*
F	Clearance to outside corner	*	*
G	Clearance to inside corner	*	*
H	Clearance to each side of center line extended above meter/regulator assembly	36 in. (91 cm) within a height 15 feet above meter/regulator assembly	*
I	Clearance to service regulator vent outlet	36 in. (91 cm)	*
J	Clearance to non-mechanical air supply inlet to building or the combustion air inlet to any other application	36 in. (91 cm)	12 in. (30 cm)
K	Clearance to mechanical air supply inlet	72 in. (182 cm)	36 in. (91 cm) above if within 10 feet horizontally
L	Clearance above paved sidewalk or paved driveway located on public property	84 in. (213 cm) <sup>3)</sup>	*
M	Clearance under veranda, porch deck or balcony	12 in. (30 cm) <sup>4)</sup>	*

1) In accordance with the current CAN/CSA B149.1 Natural Gas and Propane Installation Code.

2) In accordance with the current ANSI Z223.1 / NFPA 54 National Fuel Gas Code.

3) A vent shall not terminate directly above a sidewalk or paved driveway that is located between two single family dwellings and serves both dwellings.

4) Permitted only if veranda, porch, deck or balcony is fully open on a minimum of two sides beneath the floor.

[\*] For clearances not specified in ANSI Z223.1 / NFPA 54 or CAN/CSA B149.1, one of the following shall be indicated:

a) A minimum clearance value determined by testing in accordance with section 2.20, or;

b) A reference to the following footnote:

“Clearance in accordance with local installation codes and the requirements of the gas supplier.”

## ● Non-direct

If, at any time, the installation location could experience negative pressure, there is a possibility of back-drafting cold air through the boiler's heat exchanger. This situation could lead to the freezing of the heat exchanger and malfunction of the boiler.

However, building codes in most jurisdictions disallow negative pressures in residences. In a home with a well-balanced air supply, the heat exchanger should not be in danger of freezing. Because the cause of back-drafting is not considered a manufacturing problem, any freezing damage which occurs from back-drafting will not be covered by the Custom Comfort warranty. If there is any question about the possibility of back-drafting in the installation location, use a direct venting system for the boiler. When installed in a manufactured home (mobile home), all combustion air must be supplied from the outdoors as described on page 27. When using non-direct venting, maintain non-direct vent clearances shown on page 29 as required by ANSI Z21.10.3 and the National Fuel Gas Code, ANSI Z223.1/NFPA 54, and CAN/CSA B149.1 Natural Gas and Propane Installation Code.

To use non-direct venting for the boiler:

- Insert the elbow into the intake air duct.

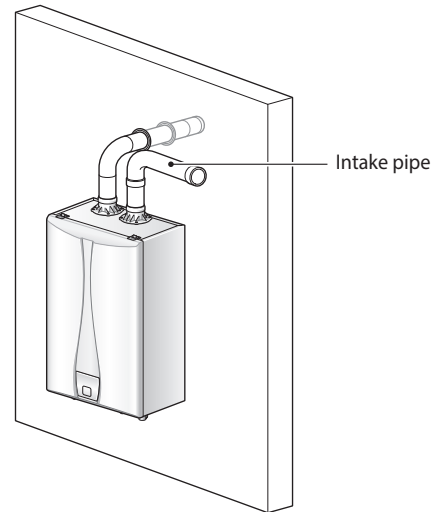

- Provide two openings to allow for circulation of combustion air as specified by ANSI Z223.1/NFPA 54 or CAN/CSA B-149.1:

	Maximum Input (BTU/H)	If outdoor make up air is provided, a minimum free area of 1 in <sup>2</sup> per 4,000 BTU/H	If indoor make up air is provided, a minimum free area of 1 in <sup>2</sup> per 1,000 BTU/H
CCOCB 80155A	155,000	40 in <sup>2</sup> 10" (W) x 4" (H) or 7" round	150 in <sup>2</sup> 12 1/4" (W) x 12 1/4" (H)
CCOCB 100180A	180,000	45 in <sup>2</sup> 10" (W) x 5" (H) or 8" round	175 in <sup>2</sup> 13 1/4" (W) x 13 1/4" (H)
CCOCB 120199A	199,000	50 in <sup>2</sup> 10" (W) x 5" (H) or 8" round	199 in <sup>2</sup> 14 1/4" (W) x 14 1/4" (H)
CCOCB 140199A	199,000	50 in <sup>2</sup> 10" (W) x 5" (H) or 8" round	199 in <sup>2</sup> 14 1/4" (W) x 14 1/4" (H)

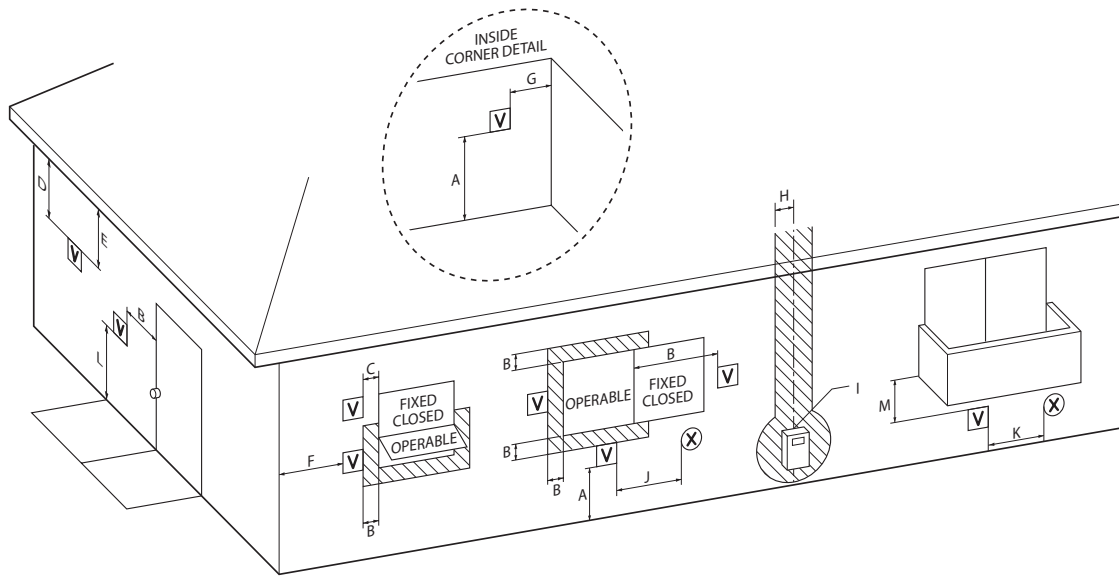

**V** VENT TERMINAL

**X** AIR SUPPLY INLET

**▨** AREA WHERE TERMINAL IS NOT PERMITTED

		Canadian Non-Direct Vent Installation <sup>1)</sup>	U.S. Non-Direct Vent Installation <sup>2)</sup>
A	Clearance above grade, veranda, porch, deck or balcony	12 in. (30 cm)	12 in. (30 cm)
B	Clearance to window or door that may be opened	36 in. (91 cm)	4 feet below or to side of opening; 1 foot above opening
C	Clearance to permanently closed window	*	*
D	Vertical clearance to ventilated soft located above the vent termination within a horizontal distance of 2 feet (61 cm) from the center line of the termination	*	*
E	Clearance to unventilated soft	*	*
F	Clearance to outside corner	*	*
G	Clearance to inside corner	*	*
H	Clearance to each side of center line extended above meter/regulator assembly	36 in. (91 cm) within a height 15 feet above meter/ regulator assembly	*
I	Clearance to service regulator vent outlet	36 in. (91 cm)	*
J	Clearance to non-mechanical air supply inlet to building or the combustion air inlet to any other application	36 in. (91 cm)	4 feet below or to side of opening; 1 foot above opening
K	Clearance to mechanical air supply inlet	72 in. (182 cm)	36 in. (91 cm) above if within 10 feet horizontally
L	Clearance above paved sidewalk or paved driveway located on public property	84 in. (213 cm) <sup>3)</sup>	84 in. (236 cm)
M	Clearance under veranda, porch deck or balcony	12 in. (30 cm) <sup>4)</sup>	*

1) In accordance with the current CAN/CSA B149.1 Natural Gas and Propane Installation Code.

2) In accordance with the current ANSI Z223.1 / NFPA 54 National Fuel Gas Code.

3) A vent shall not terminate directly above a sidewalk or paved driveway that is located between two single family dwellings and serves both dwellings.

4) Permitted only if veranda, porch, deck or balcony is fully open on a minimum of two sides beneath the floor.

[\*] For clearances not specified in ANSI Z223.1 / NFPA 54 or CAN/CSA B149.1, one of the following shall be indicated:

a) A minimum clearance value determined by testing in accordance with section 2.20, or;

b) A reference to the following footnote:

“Clearance in accordance with local installation codes and the requirements of the gas supplier.”

## Vent Pipe Materials



Caution

Venting requirements differ in the US and Canada. Consult the following chart or the most recent edition of ANSI Z223.1/ NFPA 54 or CAN/CSA B149.1, as well as all applicable local codes and regulations when selecting vent pipe materials. Do not use cellular core PVC (ASTM F891), cellular core CPVC, Radel® (polyphenolsulfone) for the exhaust vent. Covering non-metallic vent pipe and fittings with thermal insulation shall be prohibited.

Locale	Recommended Vent Materials
USA	<ul style="list-style-type: none"> <li>PVC Schedule 40 (solid core)</li> <li>CPVC Schedule 40 or 80 (solid core)</li> <li>Approved Polypropylene</li> </ul>
Canada*	<ul style="list-style-type: none"> <li>Type BH Special Gas Vent Class IIA (PVC)</li> <li>Type BH Special Gas Vent Class IIB (CPVC)</li> <li>Type BH Special Gas Vent Class IIC (Polypropylene)</li> </ul>

\* For installation in Canada, field-supplied plastic vent piping must comply with CAN/CSA B149.1 (latest edition) and be certified to the Standard For Type BH Gas Venting Systems, ULC-S636. Components of this listed system must not be interchanged with other vent systems or unlisted pipes or fittings. All plastic components and specified primers and glues of the certified vent system must be from a single system manufacturer and must not be intermixed with another system manufacturer's parts. The supplied vent connector and vent termination are certified as part of the boiler.



Caution

- This boiler has a built-in control to limit the exhaust temperature to 149°F (65°C). As a result, the Custom Comfort boiler can be vented with Schedule 40 PVC.
- In high temperature applications, the exhaust temperature can exceed 149°F (65°C). In that case, you must use Schedule 40 or 80 CPVC or Approved Polypropylene in the USA or Type BH Special Gas Vent Class IIB (CPVC) or Class IC (Polypropylene) that conforms to ULC-S636 in Canada.
- In systems with 2 in. vents, if the exhaust temperature exceeds 149°F (65°C), CPVC pipe (field supplied) must be used for the first 3 feet of equivalent pipe length. For systems with 3 in. vents, if the exhaust temperature exceeds 149°F (65°C), CPVC pipe (field supplied) must be used for the first 5 in. of equivalent pipe length.

- Generally, the boiler limits the flue gas to remain below 150°F (65°C) to use the flue pipe.
- When the return water temperature to the boiler is higher than 140°F (60°C), DIP switch #1 must be set to ON to release the flue gas limit. CPVC or PP must be used in such case.

### Notice

- PCB DIP switch #1 is set to OFF as factory default
- When you set PCB DIP switch #1 to ON, ensure that CPVC piping shall be used for exhaust venting.

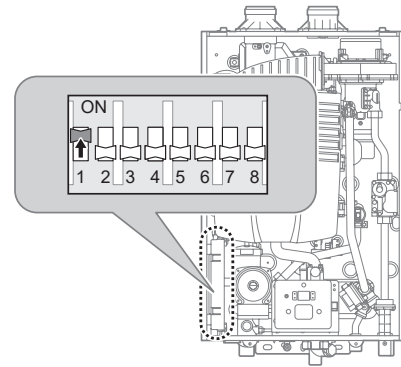

## Vent Length

The maximum vent length when using 2" exhaust ducts is 60'. The maximum vent length when using 3" vent ducts is 150'. The intake duct length can be of equal length to the exhaust duct length. Both maximum lengths are reduced by the number of elbows used, as shown in the following table:

Vent Size	Maximum Length	Maximum # of Elbows	Equivalent Lengths
2"	60' (18 m)	6	Reduce the maximum vent length accordingly for each elbow used: <ul style="list-style-type: none"> <li>Each 90° elbow equates to 8 linear feet (2.4 m) of vent</li> <li>Each 45° elbow equates to 4 linear feet (1.2 m) of vent</li> </ul>
3"	150' (45 m)	8	Reduce the maximum vent length accordingly for each elbow used: <ul style="list-style-type: none"> <li>Each 90° elbow equates to 5 linear feet (1.5 m) of vent</li> <li>Each 45° elbow equates to 3 linear feet (0.9 m) of vent</li> </ul>

### Notice

- The maximum length does not include any elbows.
- If using a concentric termination as shown on pages 33, count this as 8 linear feet (2.4 m) of vent.

## Connecting the Vent Clip



To connect the exhaust vent firmly, must use the vent clip included with boiler.

### To connect the vent clip:

- 1 Connect the vent clip to the exhaust vent.



- 2 Connect the exhaust vent and the vent clip to the flue connector.

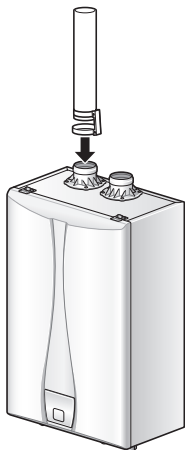

- 3 Tighten the screws and fix the vent clip.

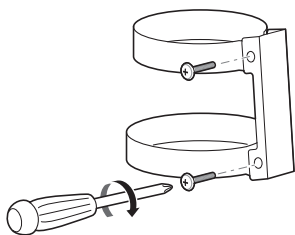

## Vent Termination



Caution

- Air intake must be protected from any debris.
- When connecting to the air intake connector and exhaust flue connector, all connecting parts must be installed properly.
- Maintain 12" (300 mm) min. (18" (450 mm) min. for Canada) clearance above highest-anticipated snow level. Maximum of 24" (600 mm) above roof.
- Install a bird screen at the end of the intake air pipe and exhaust pipe.

Before installing the boiler, determine what type of vent termination is appropriate for the installation location and situation. The subsections that follow describe some typical venting configurations, but do not include all possible options.

### Single-pipe sidewall venting

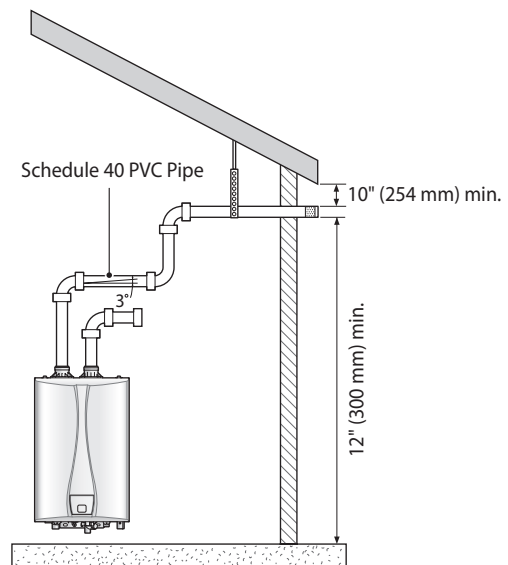

Caution

- Maintain 12" (300 mm) min. (18" (450 mm) min. for Canada) clearance above highest-anticipated snow level. Maximum of 24" (600 mm) above roof.
- Install a bird screen at the end of the intake air pipe and exhaust pipe.

#### Notice

Single-pipe venting requires that adequate combustion air be provided in end-use installations per NFPA 54 C.9.3.2.

## Two-pipe sidewall venting

### Internal view

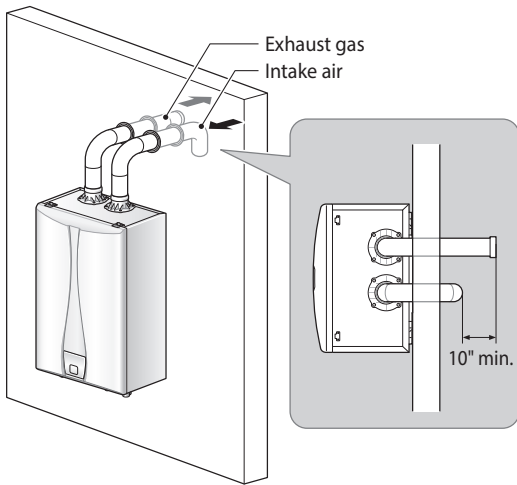

### External view

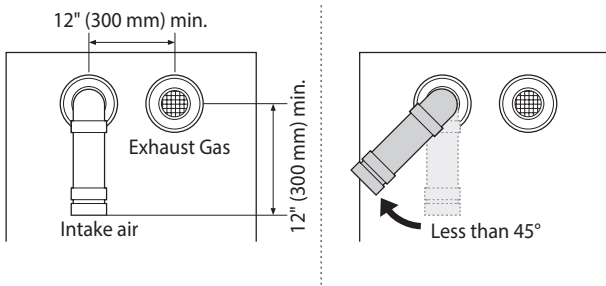

**Caution**

- Maintain 12" (300 mm) min. (18" (450 mm) min. for Canada) clearance above highest-anticipated snow level. Maximum of 24" (600 mm) above roof.
- Install a bird screen at the end of the intake air pipe and exhaust pipe.

### Notice

It is recommended to install the intake air vent terminal as far from the exhaust gas vent terminal as possible.



**Caution**

If the side wall vent termination kit is used, refer to the figure below for the orientation of the vent.

The following terminations can also be used:

- IPEX Low Profile Termination Kits:
- 2 in Low Profile Vent Kit #196984
  - 3 in Low Profile Vent Kit #196985

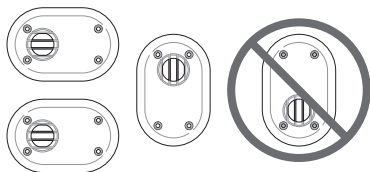

## Snorkel flue

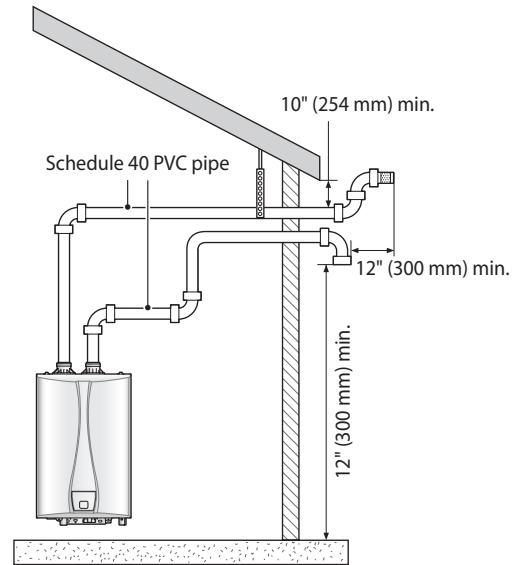

**Caution**

- Maintain 12" (300 mm) min. (18" (450 mm) min. for Canada) clearance above highest-anticipated snow level. Maximum of 24" (600 mm) above roof.
- Install a bird screen at the end of the intake air pipe and exhaust pipe.

## Non-concentric sidewall venting

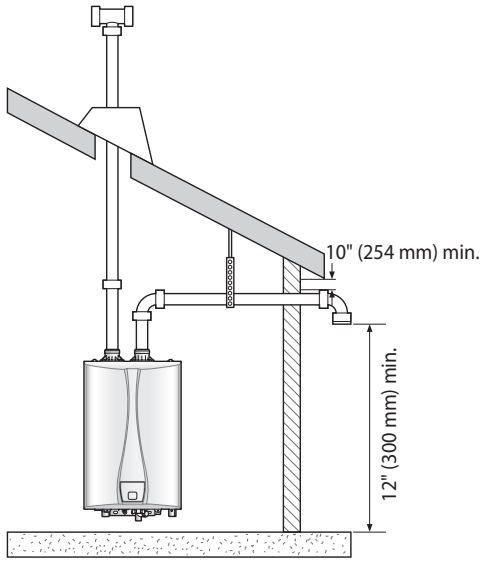

- Maintain 12" (300 mm) min. (18" (450 mm) min. for Canada) clearance above highest-anticipated snow level. Maximum of 24" (600 mm) above roof.
- Install a bird screen at the end of the intake air pipe and exhaust pipe.

### Notice

Air is drawn from a different location at a minimum of 12" (300mm) from the exhaust termination. Try to minimize the length of the intake air pipe with this venting.

## Two-pipe vertical venting

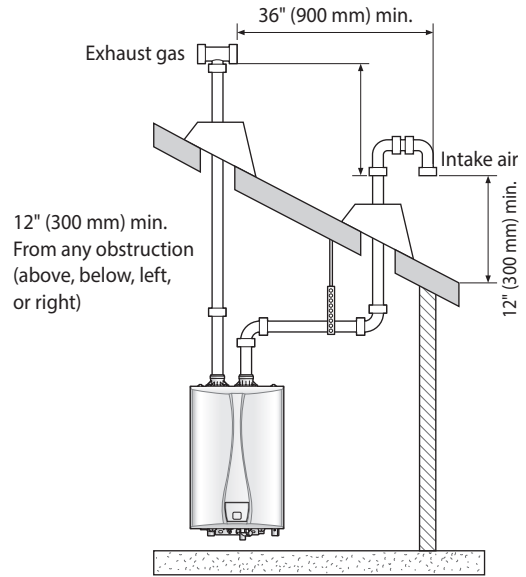

- Maintain 12" (300 mm) min. (18" (450 mm) min. for Canada) clearance above highest-anticipated snow level. Maximum of 24" (600 mm) above roof.
- Install a bird screen at the end of the intake air pipe and exhaust pipe.

### Notice

Intake and exhaust pipes do not have to terminate in the same area.

## Concentric sidewall venting

The following terminations can also be used:

Duravent PolyPro Horizontal Concentric Termination Kit.

- 2 in x 4 in Concentric Vent Kit #2PPS-HK
- 3 in x 5 in Concentric Vent Kit #3PPS-HK

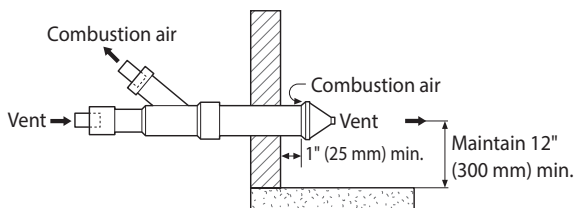

Maintain 12" (300 mm) min. (18" (450 mm) min. for Canada) clearance above highest-anticipated snow level. Maximum of 24" (600 mm) above roof.

## Concentric roof venting

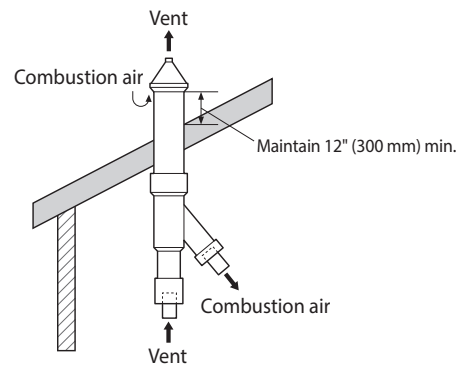

Maintain 12" (300 mm) min. (18" (450 mm) min. for Canada) clearance above highest-anticipated snow level. Maximum of 24" (600 mm) above roof.



# Setting the DIP Switches

The boiler has a DIP switch on the main circuit board(PCB)

Set the DIP switch appropriately, depending on the installation environment.

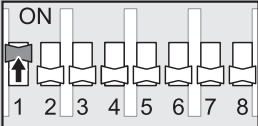
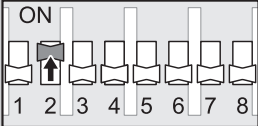
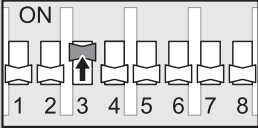
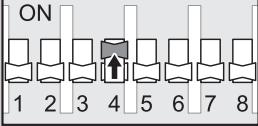
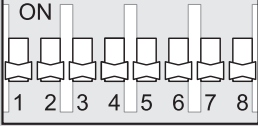
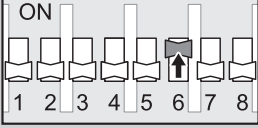
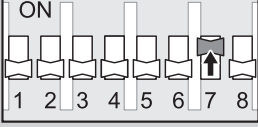
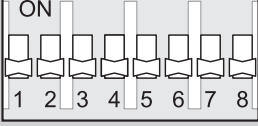
Switch	Function																					
	Temperature limit switch for exhaust gas	ON: No temperature limit for exhaust gas OFF: Temperature limit for exhaust gas																				
	EEP ROM data change switch	ON: Enable EEP ROM data change OFF: Disable EEP ROM data change																				
	Long flue Length 1	<table border="1"> <thead> <tr> <th rowspan="2">DIP S/W #3</th> <th rowspan="2">DIP S/W #4</th> <th colspan="2">FLUE LENGTH</th> </tr> <tr> <th>2" PVC</th> <th>3" PVC</th> </tr> </thead> <tbody> <tr> <td>OFF</td> <td>OFF</td> <td>Up to 15'</td> <td>Up to 150'</td> </tr> <tr> <td>OFF</td> <td>ON</td> <td>Up to 30'</td> <td rowspan="2">N/A</td> </tr> <tr> <td>ON</td> <td>OFF</td> <td>Up to 45'</td> </tr> <tr> <td>ON</td> <td>ON</td> <td>Up to 60'</td> </tr> </tbody> </table>	DIP S/W #3	DIP S/W #4	FLUE LENGTH		2" PVC	3" PVC	OFF	OFF	Up to 15'	Up to 150'	OFF	ON	Up to 30'	N/A	ON	OFF	Up to 45'	ON	ON	Up to 60'
DIP S/W #3	DIP S/W #4				FLUE LENGTH																	
			2" PVC	3" PVC																		
OFF	OFF		Up to 15'	Up to 150'																		
OFF	ON	Up to 30'	N/A																			
ON	OFF	Up to 45'																				
ON	ON	Up to 60'																				
	Long flue Length 2																					
	N/A	N/A																				
	Minimum heat capacity operation	ON : Minimum operation OFF : Normal operation																				
	Maximum heat capacity operation	ON : Maximum operation OFF : Normal Operation																				
	N/A	N/A																				

# Connecting the Power Supply

---



Warning

Improperly connecting the power supply can result in electrical shock and electrocution. Follow all applicable electrical codes of the local authority having jurisdiction. In the absence of such requirements, follow the latest edition of the National Electrical Code (NFPA 70) in the USA or the latest edition of CSA C22.1 Canadian Electrical Code Part 1 in Canada. Connecting the power supply should be performed only by a licensed professional.

When connecting the power supply, follow these guidelines:

- Do not connect the electric supply until all plumbing and gas piping is complete and the boiler has been filled with water.
- Do not connect the boiler to a 220–240V AC power supply. Doing so will damage the boiler and void the warranty.
- All boilers come with a factory-installed, 3-pronged (grounded) plug. The boiler can be plugged into any grounded electrical outlet nearby, as it requires only 5A. It is not necessary to run a dedicated electrical line to the boiler.
- If local codes require the boiler to be wired directly, remove and discard the factory-installed plug. Install a power switch between the breaker and the boiler to facilitate end-user maintenance and servicing. Connect the boiler to a 110–120V AC at 60 Hz with a maximum of 5A rating electrical supply.
- The boiler must be electrically grounded. If using the power plug, ensure that the electrical outlet you connect the boiler to is properly grounded. If wiring the boiler directly to a power supply, do not attach the ground wire to either the gas or the water piping as plastic pipe or dielectric unions may prevent proper grounding.
- We recommend using a surge protector to protect the boiler from power surges.
- If there is a power failure in cold weather areas, the freeze prevention system in the boiler will not operate and may result in freezing of the heat exchanger. In cold weather areas where power failures are common, you must completely drain the boiler to prevent damage if the power is expected to be off for any extended period of time. A battery back-up (available at most computer retailers) may be used to supply hot water during periods of power outages. Damage caused by freezing is not covered under warranty.

# Installation Checklist

After the boiler installation, examine the following checklist. If you are not able to answer "Yes" to all of the items in the checklist, review the appropriate sections. To troubleshoot any operational problems, refer to "Troubleshooting" in the User's Manual.

If there are additional questions or if you need assistance, contact technical support at 877-241-1224

Installing the boiler	Check
Have you maintained the required clearances from building openings and intake air vents?	<input type="checkbox"/>
Have you minimized the distance between the boiler and the vent termination?	<input type="checkbox"/>
Have you minimized the distance between the boiler and major fixtures?	<input type="checkbox"/>
Have you maintained the proper service and maintenance clearances?	<input type="checkbox"/>
Is the make-up air supply sufficient for proper operation?	<input type="checkbox"/>
Is the make-up air supply free from dust, dirt, corrosive elements, and flammable vapors?	<input type="checkbox"/>
Is the boiler and vent piping clear of combustible materials, including clothing, cleaning materials, and rags?	<input type="checkbox"/>

Connecting the Gas Supply	Check
Does the gas supply match the type specified on the boiler's rating plate?	<input type="checkbox"/>
Is the gas line at least 1/2 or 3/4 in ID (Inner Diameter)?	<input type="checkbox"/>
Is the gas supply line sufficient in length and diameter to deliver the required BTUs?	<input type="checkbox"/>
Have you measured the pressure of the gas supply line?	<input type="checkbox"/>
Is the gas supply pressure within the recommended ranges specified in this manual?	<input type="checkbox"/>
Is the gas supply line equipped with a manual shut-off valve?	<input type="checkbox"/>
Have you tested the gas line pressure and all fittings for leaks?	<input type="checkbox"/>
Has the gas company inspected the installation, if required?	<input type="checkbox"/>

Connecting the Domestic Water Supply	Check
Is the water supply pressure sufficient (greater than 40 psi)?	<input type="checkbox"/>
Have you installed shut off valves on the inlet and outlet to facilitate cleaning of the inlet water filter?	<input type="checkbox"/>
Have you bled the air out at each fixture?	<input type="checkbox"/>
Have you checked each fixture to ensure hot water is being supplied?	<input type="checkbox"/>
Have you cleaned the inlet water filter?	<input type="checkbox"/>
If you installed a recirculation line, have you insulated the hot water pipes and the return line?	<input type="checkbox"/>

Connecting the Space Heating Piping	Check
Has the system been filled (less than 30 psi) and purged of air?	<input type="checkbox"/>
Does the piping incorporate means for air removal (scoop, separator, etc.)?	<input type="checkbox"/>
Is there an expansion tank installed and set to the proper system pressure?	<input type="checkbox"/>
If antifreeze has been used, is it the proper type and is the concentration appropriate?	<input type="checkbox"/>

Connecting a Pressure Relief Valve	Check
Have you installed an approved pressure relief valve on the boiler?	<input type="checkbox"/>
Does the rating of the pressure relief valve match or exceed the maximum BTU rating of the boiler?	<input type="checkbox"/>
Is the pressure relief valve 3/4 in on the hot water outlet and 3/4 in at the pressure relief valve adapter?	<input type="checkbox"/>
Have you installed the pressure relief valve on the space heating and hot water outlet pipe near the boiler?	<input type="checkbox"/>
Have you installed a discharge drain tube from the pressure relief valve to within 6-12 in (150-300 mm) of the floor?	<input type="checkbox"/>

Operating the boiler	Check
Have you shown the owner how to clean the inlet water filter?	<input type="checkbox"/>
Have you given the Installation Manual and User's Manual to the owner for future reference?	<input type="checkbox"/>
Have you shown the owner how to shut off the gas in case of an emergency?	<input type="checkbox"/>

Connecting the Condensate Drain	Check
Have you installed a condensate drain line from the boiler to a drain or laundry tub?	<input type="checkbox"/>

Venting the boiler	Check
Have you vented the boiler with 2/3 in PVC, CPVC, Polypropylene, Type BH Special Gas Vent (ULC-S636) for Category IV boilers (Canada), or in accordance with all local codes and the guidelines in this manual?	<input type="checkbox"/>
Have you ensured that ABS or PVC cellular core pipe has not been used as venting for the boiler?	<input type="checkbox"/>
Is the vent sloped upward toward the vent termination at a rate of 1/4 in per foot (2% grade)?	<input type="checkbox"/>
Are all vent runs properly supported?	<input type="checkbox"/>
Have you properly supported the vent termination?	<input type="checkbox"/>
Have you properly sealed all air intake and exhaust joints, from the flue collar to the vent termination?	<input type="checkbox"/>
Have you installed end caps on the exhaust and intake pipes?	<input type="checkbox"/>
Have you checked the venting for leaks?	<input type="checkbox"/>
Is the vent termination at least 12 in (300mm) above the exterior grade?	<input type="checkbox"/>
Have you ensured that sufficient make-up air is available?	<input type="checkbox"/>
Is the total vent length within the maximum vent length restriction?	<input type="checkbox"/>

Connecting the Power Supply	Check
Is the supplied voltage 110–120V AC?	<input type="checkbox"/>
Is the boiler plugged into a properly grounded outlet?	<input type="checkbox"/>
If you have made a direct power supply connection, have you installed a power switch to facilitate end-user maintenance?	<input type="checkbox"/>
Have you checked the polarity of the electrical connection?	<input type="checkbox"/>
Is the system properly set up for cascading operation (master and slave boiler), if applicable?	<input type="checkbox"/>

# Operating the Boiler

## ■ Turning the Boiler On or Off

To turn the Boiler on or off, press the  button.

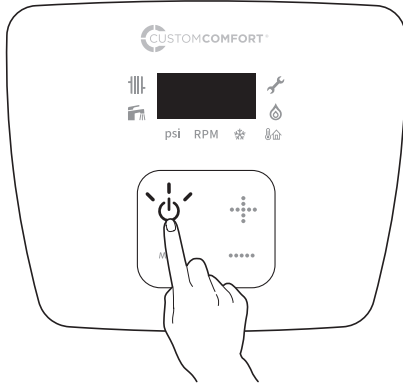

When the boiler is on, the water temperature which has been set recently will appear on the digital display.

## ■ Checking the ignition system

- 1 To turn the boiler on, press the power button.
- 2 After checking combustion, close the manual gas shutoff valve.

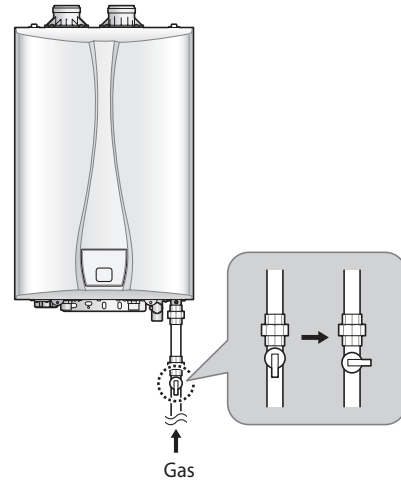

- 3 Check that the combustion lamp is off on the digital display.

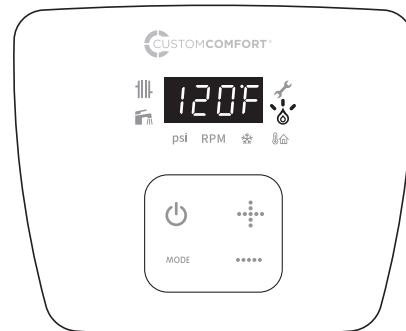

- 4 If the lamp does not turn off, contact the installer or supplier.

## Setting the Space Heating Temperature



If your household includes children, or elderly or disabled individuals, consider using a lower temperature setting.

To set the space heating water temperature.

- 1 Press the MODE button until the icon turns on.

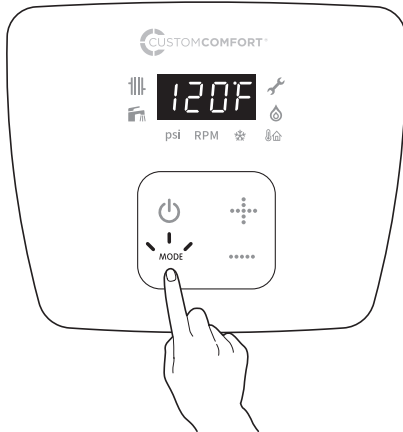

- 2 Press the or buttons until the desired temperature appears on the digital display.

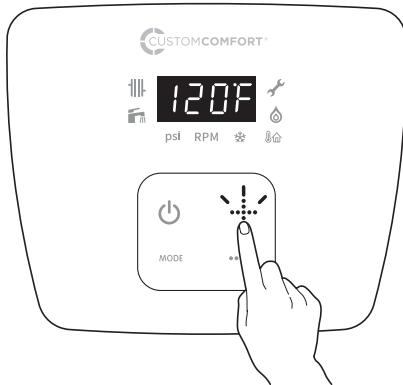

Temperature range	Adjusting the water temperature
82–180°F (Fahrenheit mode)	2°F increments
27–82°C (Celsius mode)	1°C increments

## Setting the DHW(Domestic Hot Water) Temperature



Water above 120°F (50°C) can cause instant scalding, severe burns, or death.

To adjust the water temperature:

- 1 Press the Mode button until the icon turns on.

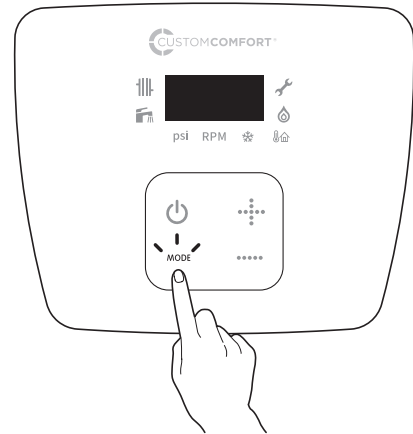

- 2 Press the or buttons until the desired temperature appears on the display.

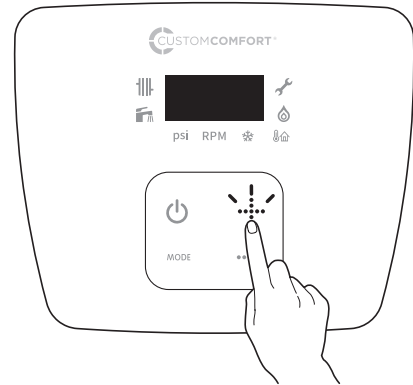

Temperature range	Adjusting the water temperature
86–120°F (Fahrenheit mode)	2°F increments
31–50°C (Celsius mode)	1°C increments (31–45°C) & 46, 48, 50°C
130°F, 140°F 55°C, 60°C	10°F or 5°C increments





### Notice

To change the temperature over 120°F, hold down button for 5 sec to unlock.

## ■ Viewing Basic Information

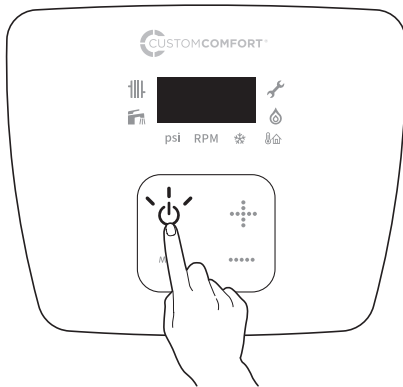
To turn the boiler on, press the  button.



To view information about the boiler, press the MODE and  buttons for 5 seconds.

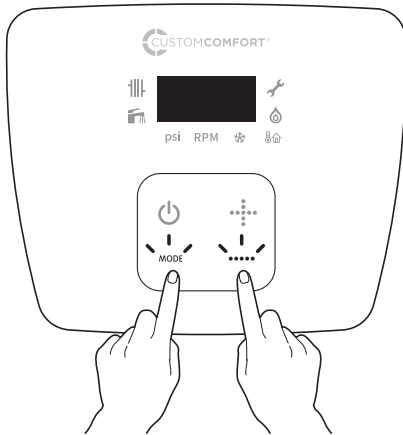

Press the MODE button to switch between the information types.

## ● H0

- This is the mode for checking the previous error.
- H0 and the previous error (example: A6) will be displayed repeatedly on the screen.

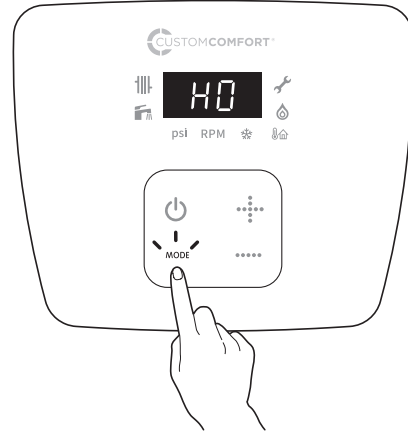

## ● H1

- This is the mode for checking the most recent error.
- H1 and the most recent error (Example : A2) will be displayed repeatedly on the screen.

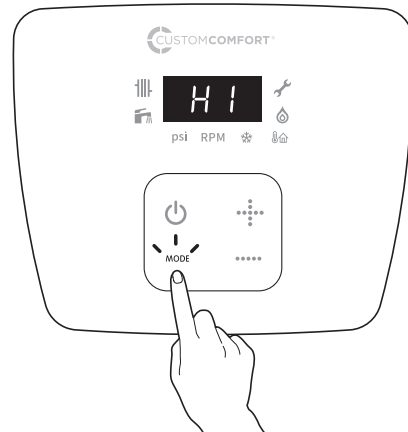



## H2

- This is the mode for checking the current error.
- H2 and the current error (Example : A3) will be displayed repeatedly on the screen.

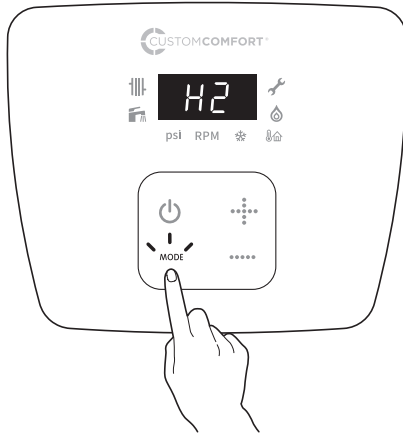

## H4

- This is the mode for checking the current number of revolutions of the fan.
- H4 and the current number of revolutions of the fan (Example : 3600) will be displayed repeatedly on the screen.
- The unit is rpm.

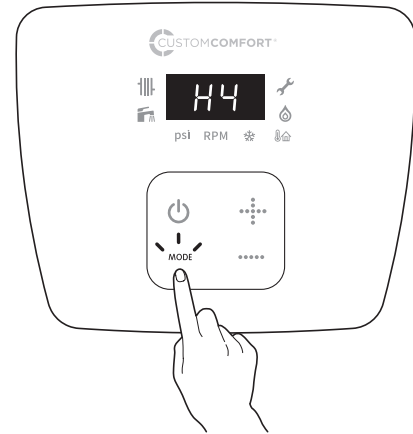

## H3

- This is the mode for checking the current pressure in the system.
- H3 and the current pressure in the boiler (Example : 25) will be displayed repeatedly on the screen.
- The pressure unit is PSI.

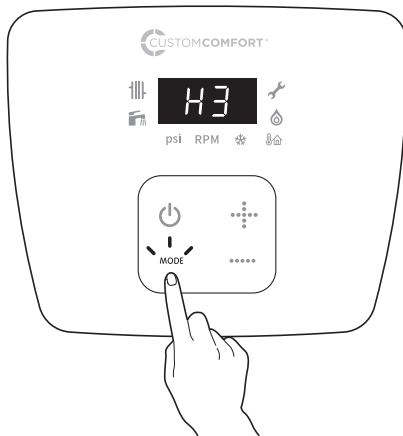

## H5

- This is the mode for checking the output voltage of the fan.
- H5 and the output voltage (Example : C5) will be displayed repeatedly on the screen.

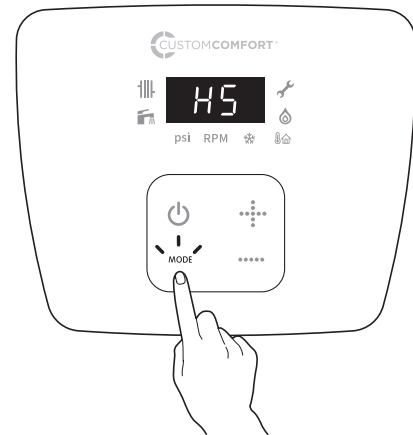

## H6

- This is the mode for checking the current exhaust gas temperature.
- H6 and the current exhaust gas temperature (example: 120) will be displayed repeatedly on the screen.
- The unit is °F.

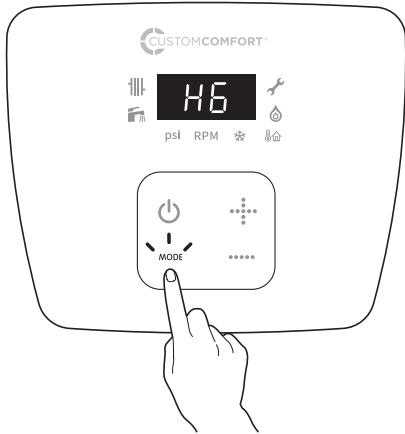

## H8

- This is the mode for checking the current ambient temperature.
- H8 and the current ambient temperature (example: 25) will be displayed repeatedly on the screen.
- The unit is °F.

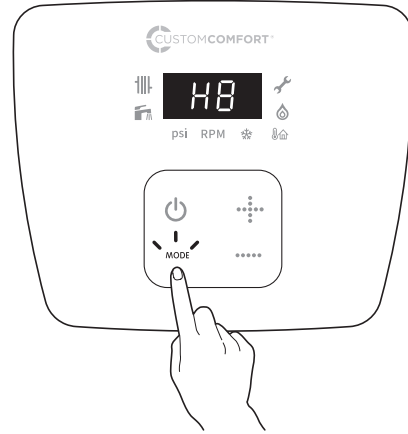

## H7

- This is the mode for checking the current hot water temperature.
- H7 and the hot water temperature (example: 100) will be displayed repeatedly on the screen.
- The unit is °F.
- If using the VRB boiler, 00 will be displayed.

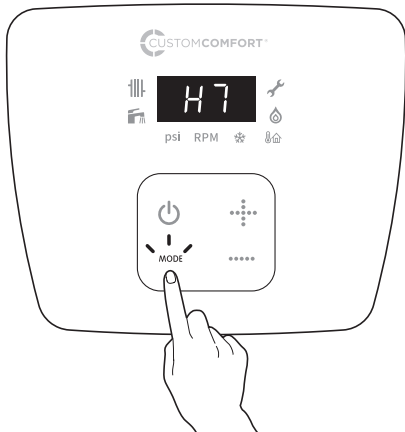

## H9

- This is the mode for checking the return temperature of the boiler.
- H9 and the return temperature (example: 120) will be displayed repeatedly on the screen.
- The unit is °F.

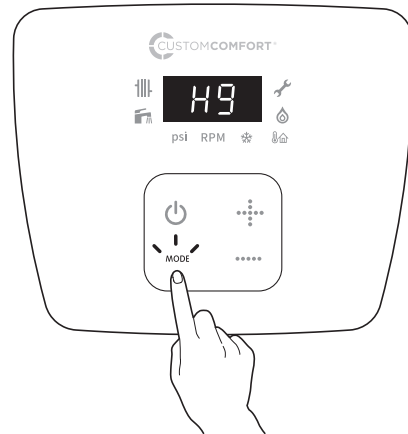

## HA

- This is the mode for checking the hot water and heating modes.
- HA and the heating mode or the hot water mode (example: FF or 00) will be displayed repeatedly on the screen.
- FF is the current hot water mode, and 00 is the heating mode.

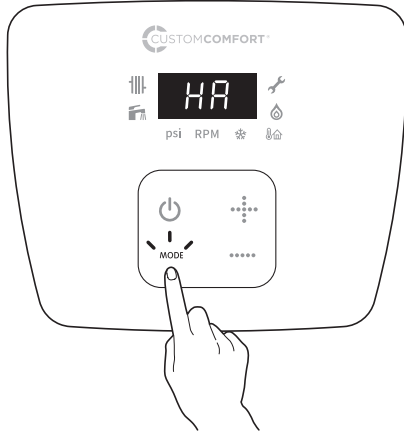

## HB

- This is the mode for checking the current PCB version (example: 1.0).
- HB and the PCB version will be displayed repeatedly on the screen.

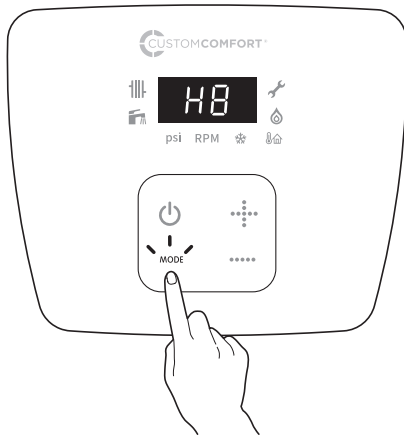

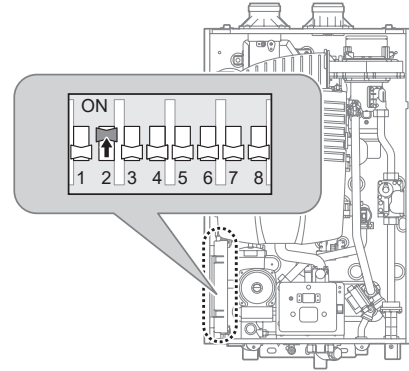

## Setting the Heat Load for The Outdoor Reset Control Mode

- Move No. 2 PCB DIP switch in the ON direction.

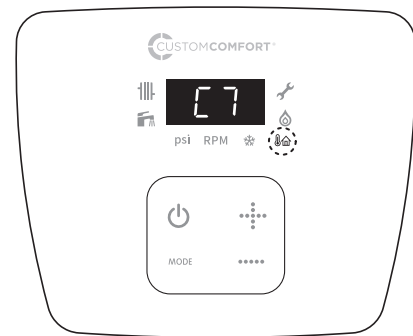

- Press the MODE and  buttons for 5 seconds. The outdoor reset lamp will turn on, and C7 and ON or OFF will be displayed repeatedly on the screen.



- At this time, you can set ON or OFF using the  or  button.  
C7 : ON = The boiler operates in outdoor reset mode using the ambient temperature sensor.  
C7 : OFF = The boiler operates according to the heating water temperature.



- When you set ON for C7 and press the MODE button, C8 and "1" will be displayed repeatedly.
- You can set a value from 0 to 6 using the  $\cdot\cdot\cdot\cdot$  and  $\cdot\cdot\cdot\cdot$  buttons. (The factory default value is 1.) The meaning of each number is as follows.

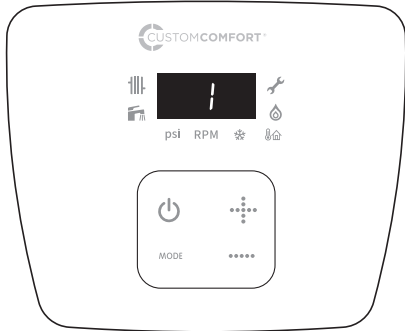

### Outdoor reset heat load types

- 0: Finned tube heat load types
- 1: Fan coil
- 2: Cast iron baseboard
- 3: Low mass radiant
- 4: High mass radiant
- 5: Radiator
- 6: Custom

The set temperature for each heat load type is as follows.

Heat load	Minimum set-point	Maximum set-point	Out temperature Min-maximum
Finned tube heat load types	118°F(48°C)	180°F(82°C)	Minimum out temperature: 14°F(-10°C)
Fan coil	120°F(60°C)	180°F(82°C)	
Cast iron baseboard	100°F(38°C)	170°F(77°C)	Maximum out temperature: 68°F(20°C)
Low mass radiant	82°F(28°C)	140°F(60°C)	
High mass radiant	82°F(28°C)	122°F(50°C)	
Radiator	118°F(48°C)	170°F(77°C)	
Custom	User define		

- When "6"(custom mode) is set for C8, the user can set the temperature.
- By pressing the MODE button, the user can enter modes such as C9, CA, Cb, and CC, and can set the temperature.
- The content of each mode is as follows.
- custom setting the lowest space heating temperature

Display	Description
C6 82°F	<ul style="list-style-type: none"> <li>• Temperature range: 82°F(28°C) – 118°F(48°C)</li> </ul>

- custom setting the highest space heating temperature

Display	Description
CC 122°F	<ul style="list-style-type: none"> <li>• Temperature range: 122°F(50°C) – 180°F(82°C)</li> </ul>

- custom setting the lowest outdoor temperature

Display	Description
C9 32°F	<ul style="list-style-type: none"> <li>• Temperature range: -4°F(-20°C) – 32°F(0°C)</li> </ul>

- custom setting the highest outdoor temperature

Display	Description
CA 86°F	<ul style="list-style-type: none"> <li>• Temperature range: 34°F(1°C) – 86°F(30°C)</li> </ul>

# Appendix

## Gas Conversion

This boiler is configured for Natural Gas from the factory. If conversion to Propane Gas is required, the conversion kit supplied with the boiler must be used.



**Danger**

Inspect the packing between the gas valve and gas pipe whenever they are disassembled. The packing must be installed and must be in good condition. Failure to comply will cause a gas leak, resulting in severe personal injury or death.



**Warning**

This conversion kit shall be installed by a qualified service agency\* in accordance with Custom Comfort instructions and all applicable codes and requirements of the authority having jurisdiction. The information in these instructions must be followed to minimize the risk of fire or explosion and/or to prevent property damage, personal injury or death. The qualified service agency is responsible for the proper installation of this kit. The installation is not proper and complete until the operation of the converted appliance is checked as specified in the manufacturer's instructions supplied with the kit.

\* A qualified service agency is any individual, firm, corporation or company which either in person or through a representative is engaged in and is responsible for the connection, utilization, repair or servicing of gas utilization equipment or accessories; who is experienced in such work, familiar with all precautions required, and has complied with all of the requirements of the authority having jurisdiction.

In Canada: The conversion shall be carried out in accordance with the requirements of the provincial authorities having jurisdiction and in accordance with the requirements of the CAN/CSA B149.1 and CAN1 B149.2 Installation Codes.

Included Items (Item No ; CCOB2110399S)

- Inline Orifice
- 3/4" Gasket Packing
- Conversion Manual
- Rating Plate(Conversion sticker)

To convert the gas:

- 1 Turn off the manual gas shut off valve and the water supply to the boiler.

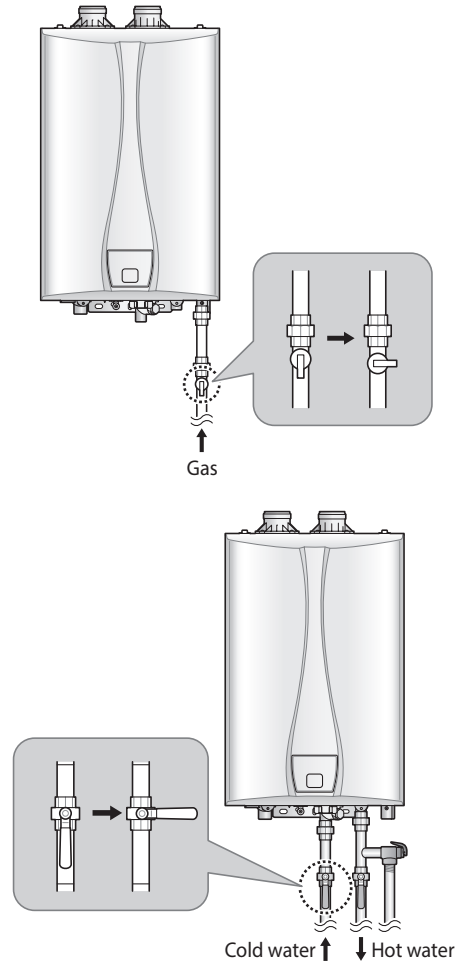

- 2 Remove the boiler front cover by loosening the 2 Phillips screws securing it to the case.

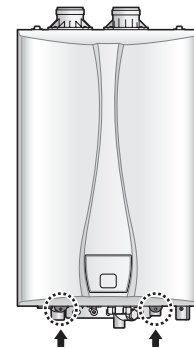

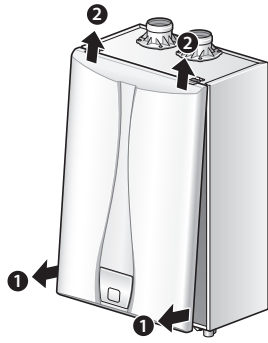

- 3** Once the front cover is removed, place it in a safe location to prevent accidental damage. With the internal components exposed, locate the gas connector and the gas valve.

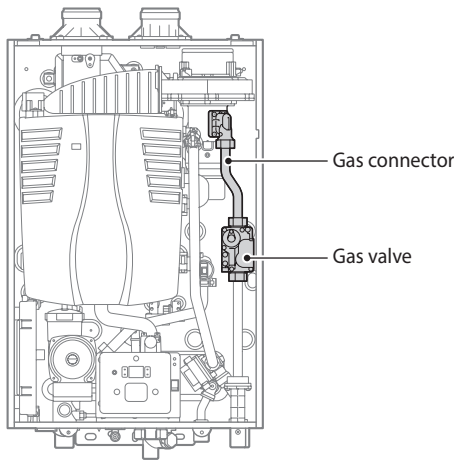

- 4** Loosen the nut connecting the gas connector and the gas valve. Carefully separate the gas inlet pipe.

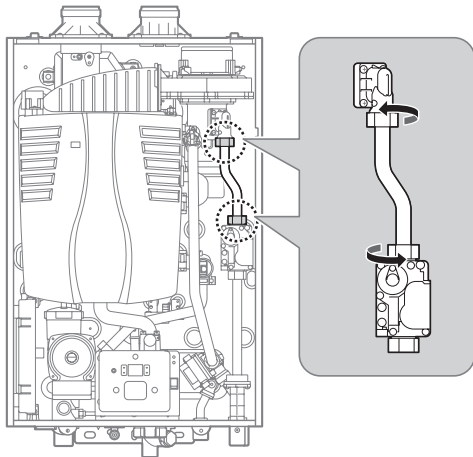

- 5** Insert the "Inline Orifice" into top of the gas valve. Then place the 3/4" packing gasket on top of the "Inline Orifice" and threaded nipple.

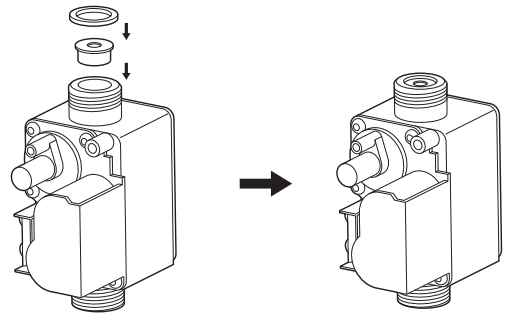

- 6** Tighten the nut connecting the gas connector and gas valve. Careful to install the 3/4" packing gasket correctly.

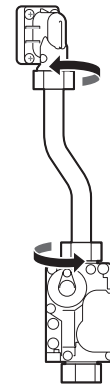

- 7** Remove the front sealing packing of the two from the silence.



Be careful not remove the rear sealing packing instead of the front sealing packing.

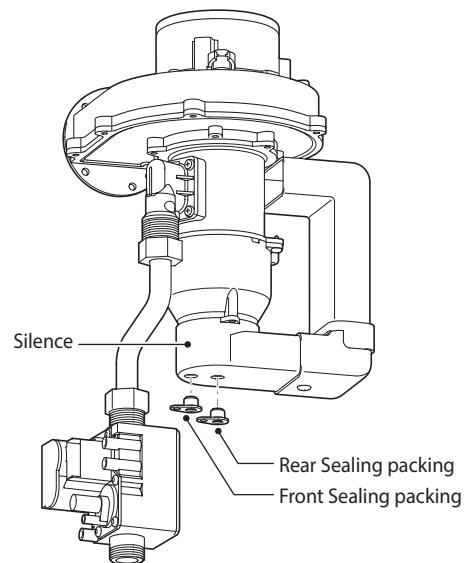

- 8 Check the gas leakage before operating the water heater.
- 9 Turn on the gas and water supply to the boiler.
- 10 Set the DIP switch to minimum heat capacity operation.



Be sure to turn off the power before changing the DIP switch setting

**Notice**

For more information about setting the DIP switches, refer to "Setting the DIP Switches" on page 37.

- 11 Loosen the screw, remove the bracket and the cap to access the exhaust analyzer hole.

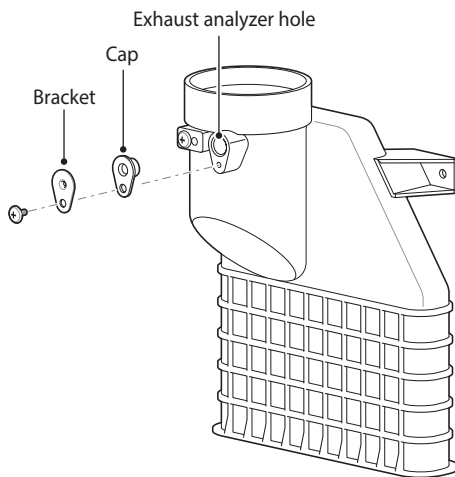
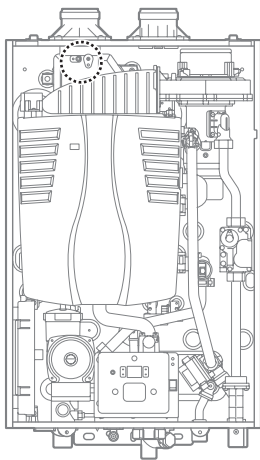

- 12 Insert analyzer into the exhaust analyzer hole and measure the gas/air ratio (using combustion analyzer is recommended).

Type	High fire			Low fire		
	CO <sub>2</sub> (%)	MAX CO (PPM)	MAXIMUM Fan (RPM)	CO <sub>2</sub> (%)	MAX CO (PPM)	MAXIMUM Fan (RPM)
NG	9.5 ± 0.5	200	6600 ± 100	9.9 ± 0.5	75	1440 ± 50
Propane	9.5 ± 0.5	200	6600 ± 100	11.5 ± 0.5	75	1440 ± 50

CO<sub>2</sub> value

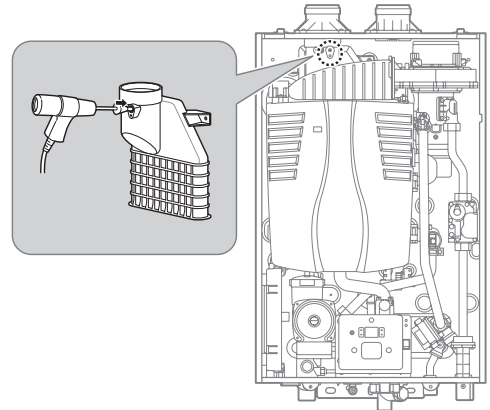

- 13 Fully open several hot water fixtures and if the CO<sub>2</sub> value at low fire is not within 0.5% of the value listed in the table above, the gas valve set screw will need to be adjusted. If adjustment is necessary, locate the set screw. Using a 5/32" or 4mm Allen wrench, turn the set screw no more than 1/4 turn clockwise to raise or counterclockwise to lower the CO<sub>2</sub> value.



Improper gas valve settings can cause severe injury, death or property damage.

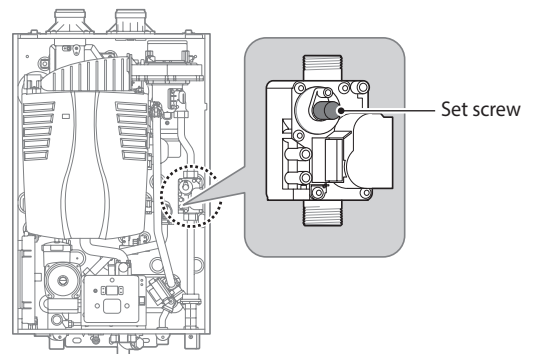

**14** Set the DIP switch to maximum heat capacity operation.



Be sure to turn off the power before changing the DIP switch setting.

 **Notice**

For more information about setting the DIP switches, refer to "Setting the DIP Switches" on page 37.

**15** Fully open several hot water fixtures and if the CO<sub>2</sub> value at high fire is not within 0.5% of the value listed in the table above, do not adjust the gas valve set screw and check if the gas orifice is properly installed.



Improper gas valve settings can cause severe injury, death or property damage.

 **Notice**

While measuring the gas/air ratio in maximum heat capacity operation, do not adjust the gas valve set screw.

**16** When the gas conversion is completed, attach the conversion sticker to the top of the rating plate.

**This appliance was converted on**  
\_\_\_\_ / \_\_\_\_ / \_\_\_\_ /  
**(day/month/year) to** \_\_\_\_\_  
**gas with Kit No.** \_\_\_\_\_  
**by** \_\_\_\_\_  
**(name and address of organization**  
**making this conversion) that accepts the**  
**responsibility for the correctness of this**  
**conversion.**

This appliance has been converted to  
Propane fuel /  
Cet appareil a été converti au propane  
Orifice Size / injecteur  
Min. 5.7mm to Max. 4.5mm  
plus Inline Orifice 5.2mm  
Inlet Gas Pressure / Pression d'entree du gaz  
Min. 8.0 to Max. 13.0" WC  
Manifold Pressure /  
Pression à la tubulure d'alimentation Min.  
0.01 to Max. -0.30(150), -0.56(199)" WC  
Input (Btu/hr) / Débit calorifique  
Min. 19,900 to Max. 150,000 – 199,000  
Conversion Kit No. CCOB2110399S

Conversion Rating Plate



# Wiring Diagram

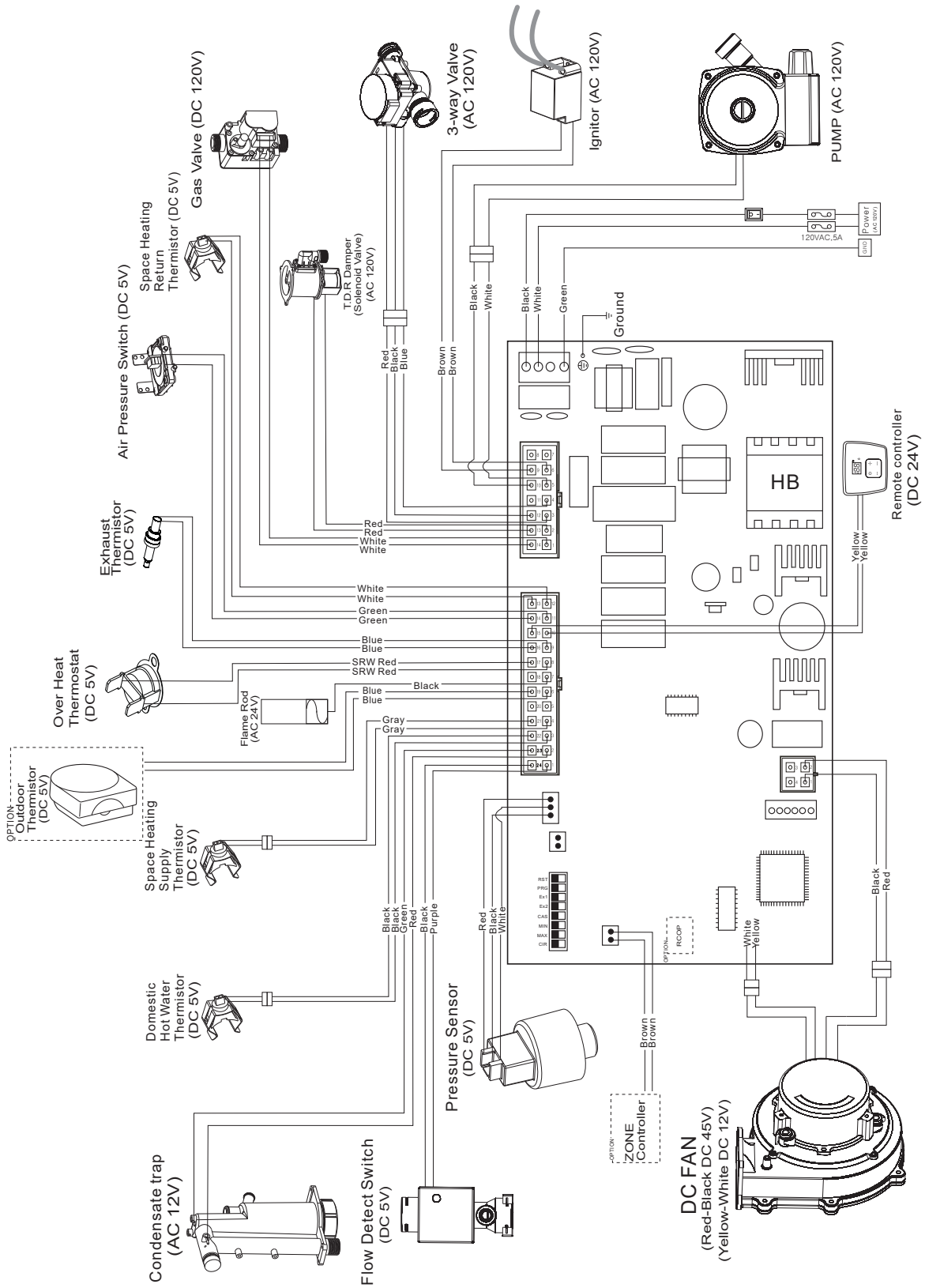

# Ladder diagram

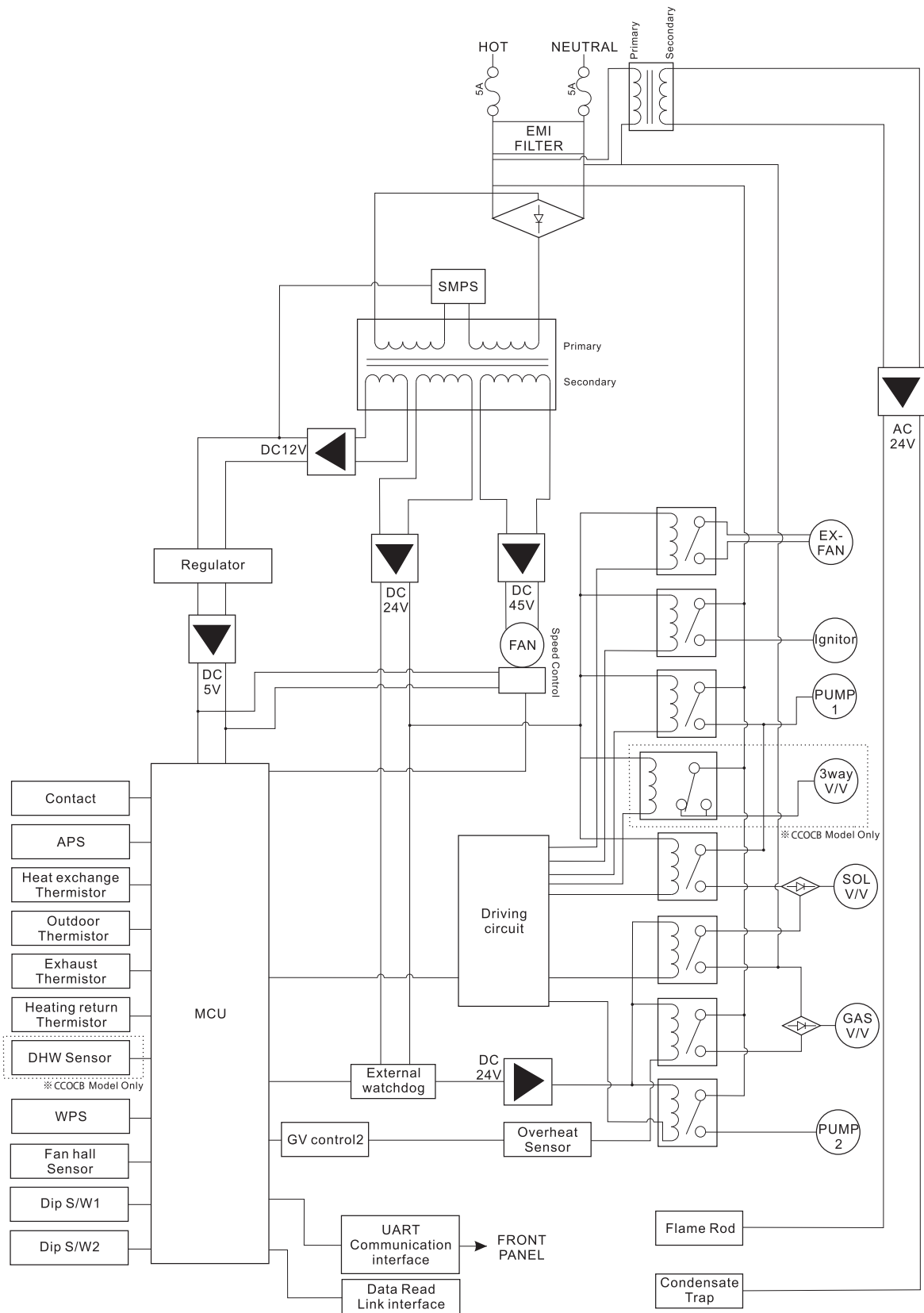

# Component Assembly Diagrams and Parts Lists

## ■ Case Parts (Combi Boiler)

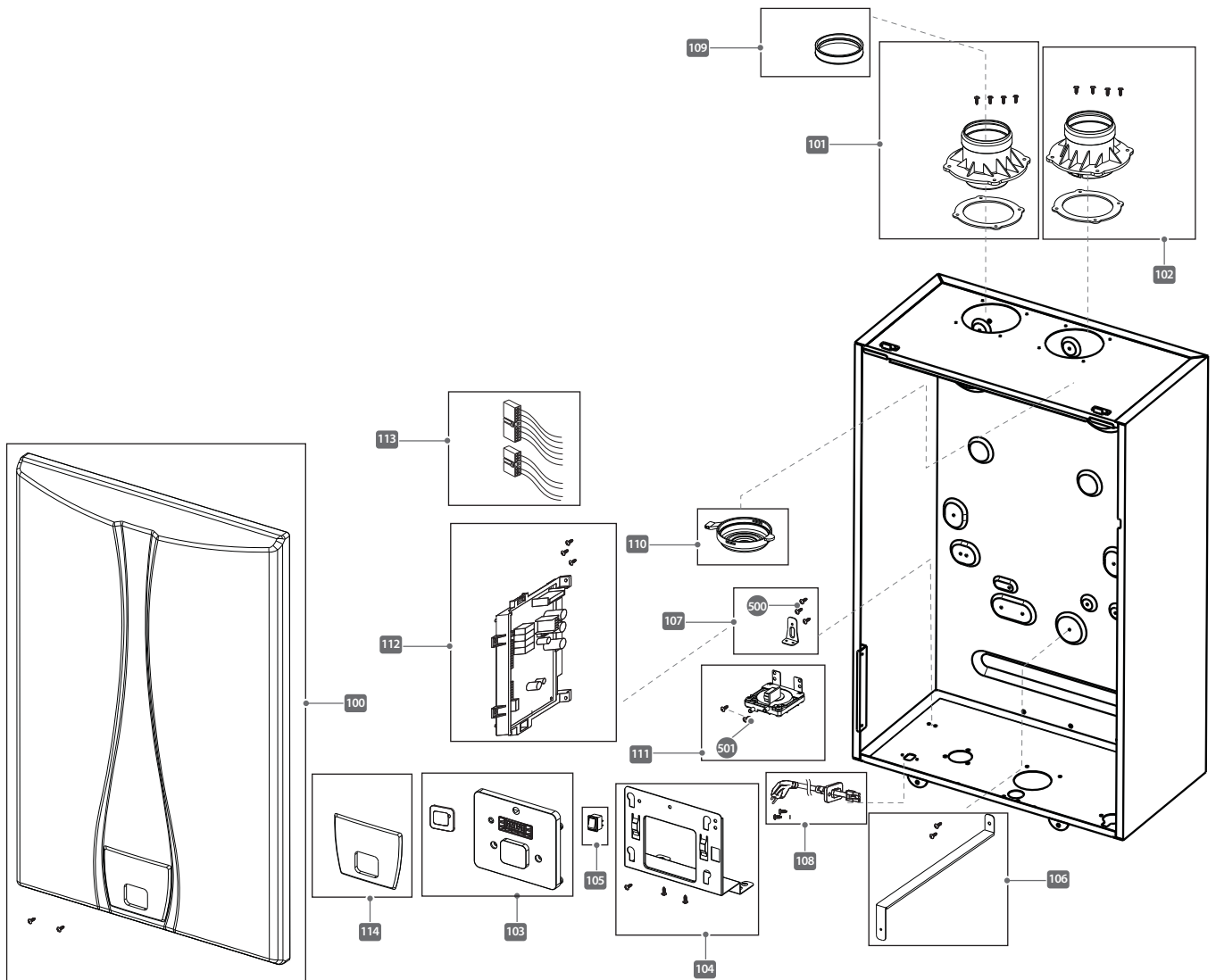

NO	Part NO	Part Name
100	CCOB2010627S	Front Cover CB80155A
	CCOB2010628S	Front Cover CB100180A
	CCOB2010629S	Front Cover CB120199A
	CCOB2010630S	Front Cover CB140199A
101	CCOB2110304S	Exhaust Adapter CB & B (A) Series All
102	CCOB2110303S	Intake Adapter CB & B (A) Series All
103	CCOB2081154S	RC Display CB (A) Series All
104	CCOB3011565S	RC Display Fixing Bracket CB & B (A) Series All
105	CCOB2080736S	Main Power Supply Switch CB & B (A) Series All
106	CCOB3011632S	RC Display Bracket Holder CB & B (A) Series All
107	CCOB3011608S	PCB Bracket CB & B (A) Series All
108	CCOB3130838S	Power Cord CB & B (A) Series All
109	CCOB3080235S	Flue Sealing O-Ring CB & B (A) Series All
110	CCOB3040604	Air Intake Filter CB & B (A) Series All
111	CCOB2100376S	Air Pressure Switch CB80155A
	CCOB2100377S	Air Pressure Switch CB100180A
	CCOB2100363S	Air Pressure Switch CB120199A & CB140199A
112	CCOB2081158S	Circuit Board CB80155A
	CCOB2081157S	Circuit Board CB100180A
	CCOB2081156S	Circuit Board CB120199A
	CCOB2081155S	Circuit Board CB140199A
113	CCOB3130805	Wire Harness CB (A) Series All
114	CCOB3040709	RC Display Cover CB (A) Series All

## Flue Parts (Combi Boiler)

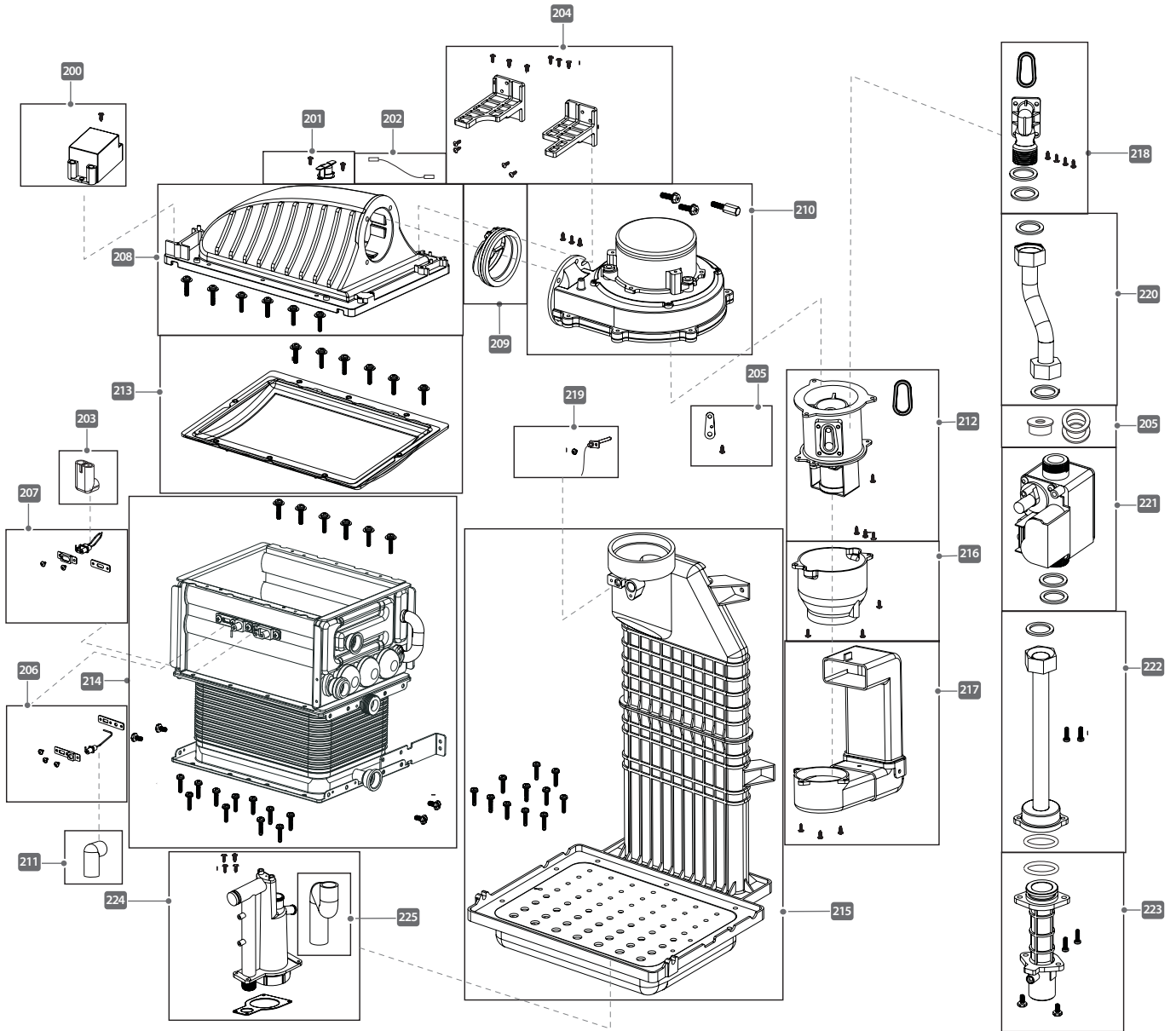

NO	Part NO	Part Name
200	CCOB2081069S	Ignition Transformer CB & B (A) All
201	CCOB2081098S	High Limit Switch Hood CB & B (A) Series All
202	CCOB3130834	High Limit Switch Wire CB & B (A) Series All
203	CCOB3080313S	Ignitor Cover CB & B (A) Series All
204	CCOB3050114S	HX Mounting Bracket CB & B (A) Series All
205	CCOB3011624S	NG Orifice CB & B (A) Series All
	CCOB3011588S	LP Orifice CB & B (A) Series All
206	CCOB2020415S	Flame Rod CB & B (A) Series All
207	CCOB2020416S	Ignitor CB & B (A) Series All
208	CCOB2130507S	Burner Hood CB & B (A) Series All
209	CCOB3080264S	Damper CB & B (A) Series All
210	CCOB2100336S	Fan CB & B (A) Series All
211	CCOB3080314S	Flame Rod Cover CB & B (A) Series All
212	CCOB2030290S	TDR Solenoid Valve CB & B (A) Series All
213	CCOB20414S	Metal Fiber Burner CB & B (A) Series All
214	CCOB2070724S	Heat Exchanger CB & B (A) Series All
215	CCOB2130508S	Exhaust Duct CB & B (A) Series All
216	CCOB3040650S	Air Mixer CB & B (A) Series All
217	CCOB2120083S	Silencer CB & B (A) Series All
218	CCOB3050112S	Gas Supply Manifold CB & B (A) Series All
219	CCOB3130751S	Exhaust Gas Thermistor CB & B & FTCB (A) Series All
220	CCOB2091076S	Gas Outlet Pipe CB & B (A) Series All
221	CCOB2030291S	Gas Valve CB & B & FTCB (A) Series All
222	CCOB2091075S	Gas Inlet Pipe CB & B (A) Series All
223	CCOB3050092S	Gas Pipe CB & B (A) Series All
224	CCOB2060374S	Condensate Trap CB & B (A) Series All
225	CCOB3080317	Condensate Hose CB & B (A) Series All

## Water Parts (Combi Boiler)

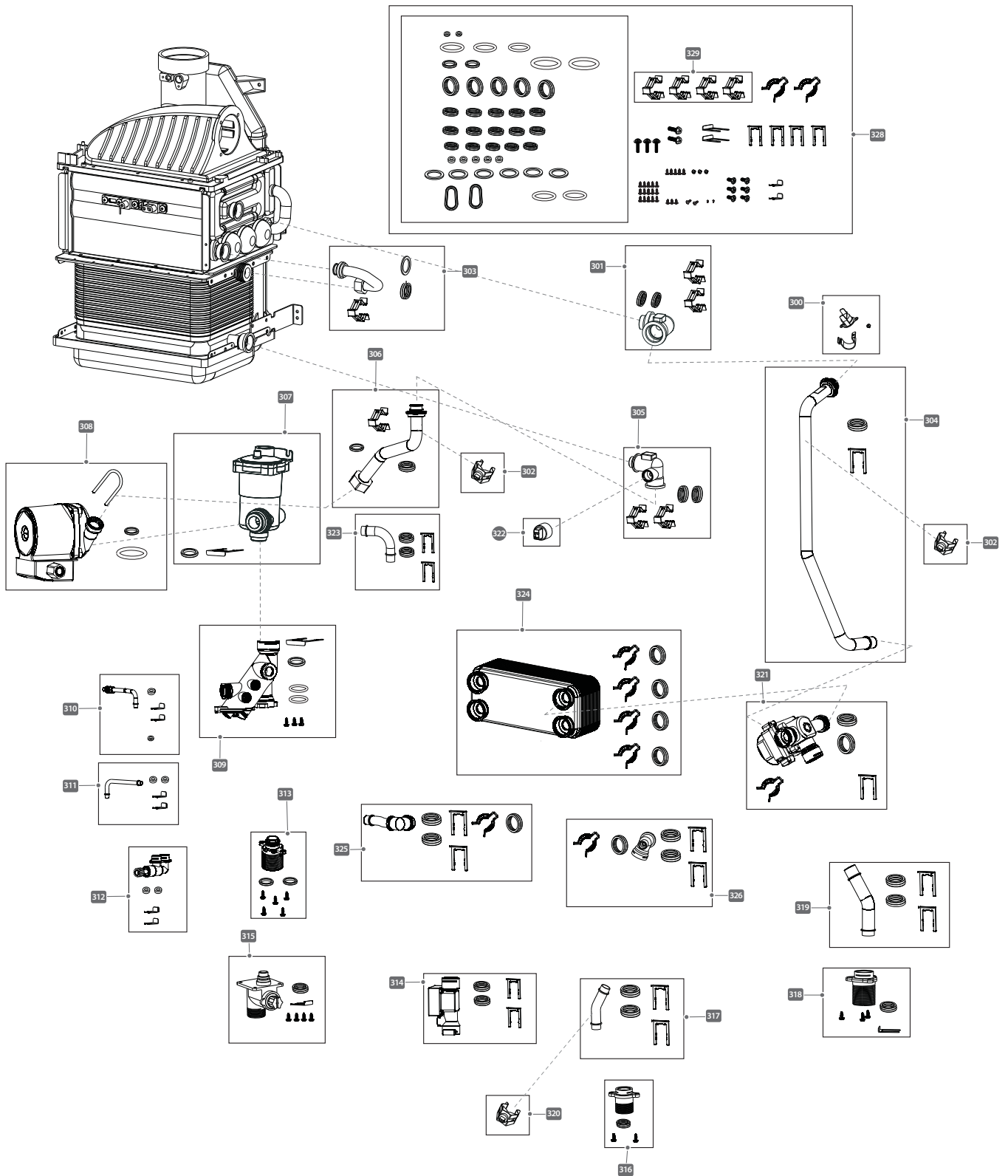

NO	Part NO	Part Name
300	CCOB2080390S	High Limit Switch CB & B (A) Series All
301	CCOB3030260S	Supply Elbow CB & B (A) Series All
302	CCOB2081174	Heating/Return Thermistor CB & B (A) Series All
303	CCOB2091134S	Heat Exchanger Connector Pipe CB & B (A) Series
304	CCOB2091131S	Supply Pipe (1) CB (A) Series All
305	CCOB3030261S	Return Connector CB & B (A) Series All
306	CCOB2091130S	Return Pipe B (A) Series All
307	CCOB2052080S	Air Vent CB (A) Series All
308	CCOB2050157S	Internal Circulation Pump CB (A) Series All
309	CCOB2060367S	Series Return Valve CB (A) All
310	CCOB2091138S	Feed Outlet Pipe CB (A) Series All
311	CCOB2091137S	Feed Inlet Pipe CB (A) Series All
312	CCOB2060228S	Manual Feed Valve CB (A) Series All
313	CCOB3030262S	Boiler Return Nipple CB (A) Series All
314	CCOB2060413S	Flow Switch CB (A) Series All
315	CCOB2060409S	Cold Water Nipple CB (A) Series All
316	CCOB3030268S	DHW Nipple CB (A) Series All
317	CCOB2091135S	DHW Pipe CB (A) Series All
318	CCOB3030269S	Heating Supply/Return Nipple CB & B (A) Series
319	CCOB2091133S	Supply Pipe (2) CB (A) Series All
320	CCOB2081032Q	DHW Thermistor CB & B (A) Series All
321	CCOB2040124S	3 Way Valve CB (A) Series All
322	CCOB2060323	Pressure Sensor for CB & B (A) Series All
323	CCOB2091136S	Cold Water Pipe CB (A) Series All
324	CCOB2060281S	Flat Plate Heat Exchanger CB (A) Series All
325	CCOB2091132S	Circulation Pipe CB (A) Series All
326	CCOB3030267S	Heat Exchanger PP Connector CB (A) Series All
327	CCOB2110332S	O-Ring Kit CB (A) Series All
328	CCOB2110335S	Screw, Packing, Clip CB (A) Series All
329	CCOB3011010S	Joint Clips 16A Kit CB & B (A) Series All



# Normal operating sequence

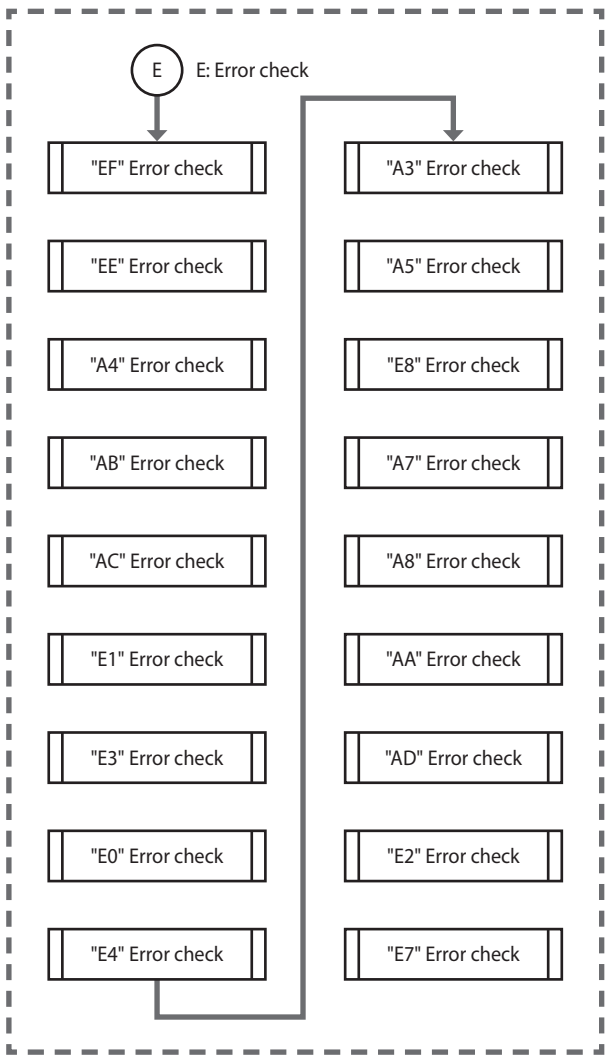
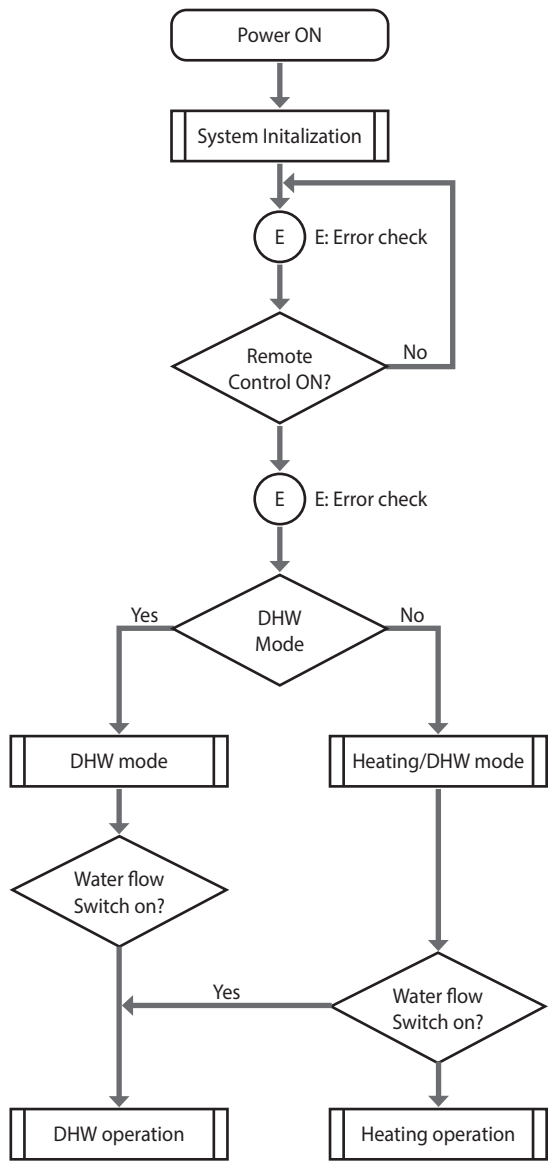

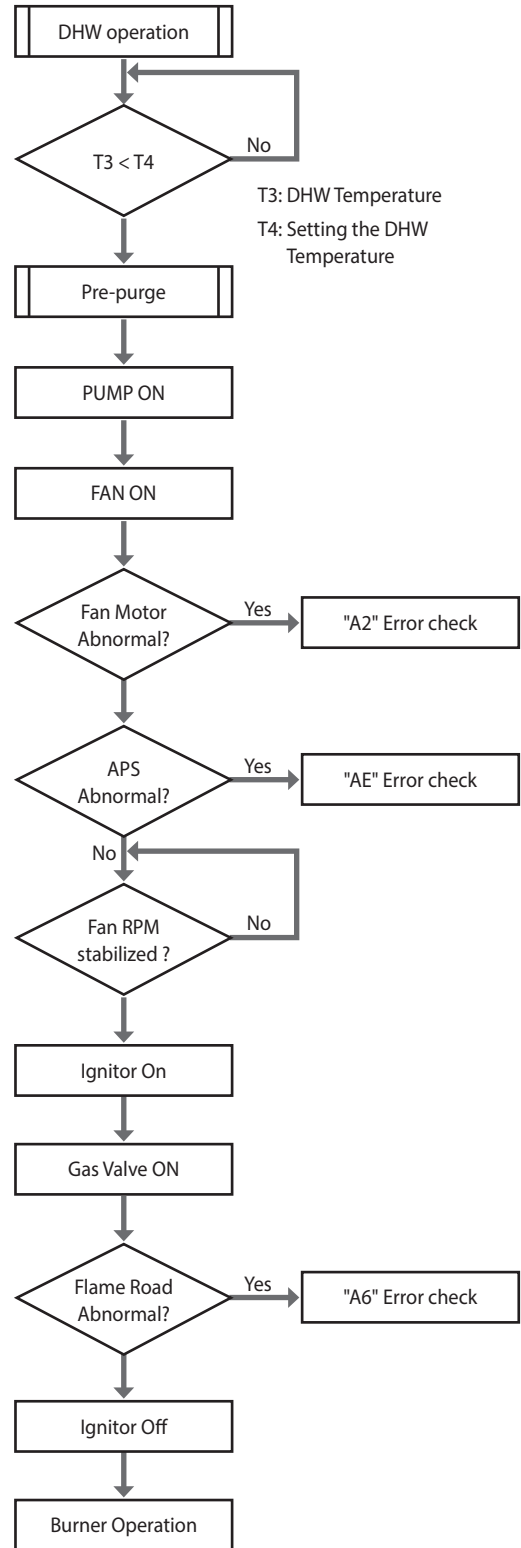
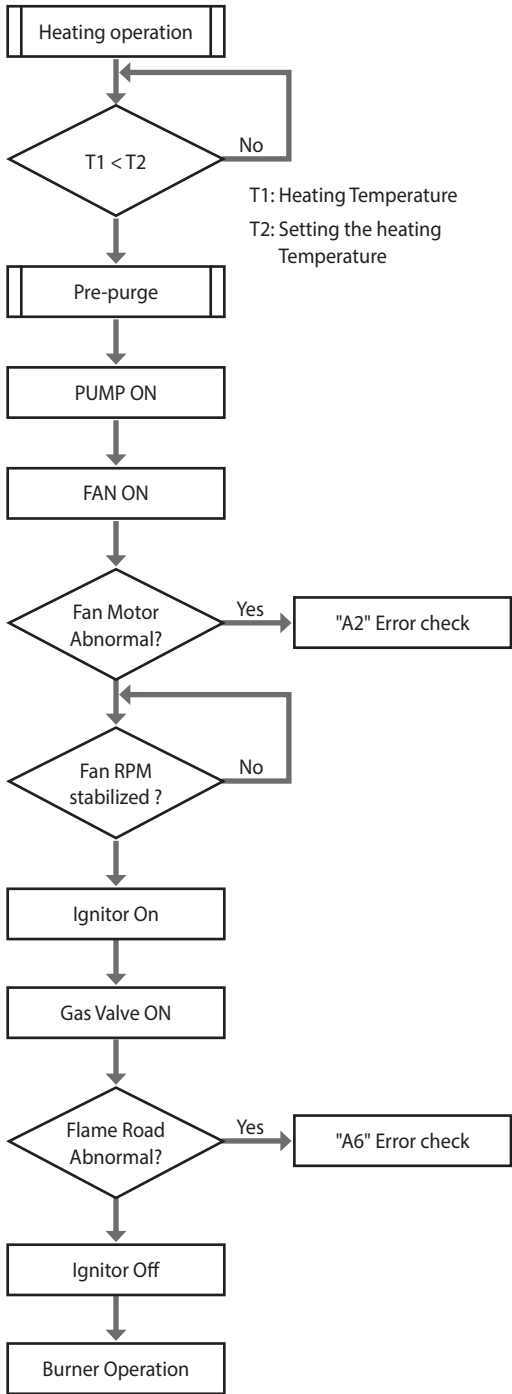

# Outdoor Temperature Sensor Installation

## Outdoor Temperature Sensor (Optional)

### Outdoor Temperature Sensor Installation

- Separate the sensor body from the sensor cap.
- Attach the sensor body to the wall using the provided screws.
- Run the wires into the device body through the grommet opening
- Connect the wires to the terminal block.
- Attach the cap to the sensor body.

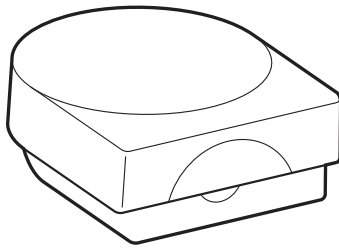

QAC 2030 (Siemens)

### Outdoor Temperature Sensor Installation Guidelines

- Avoid installing the temperature sensor in a location where the temperature may change due to direct sunlight or a location where the representative outdoor temperature is not indicated.
- The best place to install the temperature sensor is to the north or northeast of the eaves, where direct sunlight can be avoided.
- Do not install the sensor near a heat source that may affect sensing of a correct temperature (fans, exhaust vents, lights).
- Avoid installing the sensor in a location with a high amount of moisture.
- Use 18gauge wiring with no splices
- Before attaching the cap, ensure the wiring is fixed firmly.
- The sensor is a water resistant device.

## Outdoor Reset Control (Available with Optional Outdoor Temperature Sensor)

The outdoor reset control can be used in order to improve the energy efficiency. With the Outdoor Reset Control, the space heating temperature setting automatically changes according to the outdoor temperature and the current space heating system application (system load)

### Notice

The outdoor reset control can be used only when the outdoor temperature sensor is installed. In addition, it only works when the boiler is running in the normal operation mode. It does not work when the boiler is running in either the Minimum(MIN) or Maximum(MAX) mode, or When the boiler's front panel displays a fault.

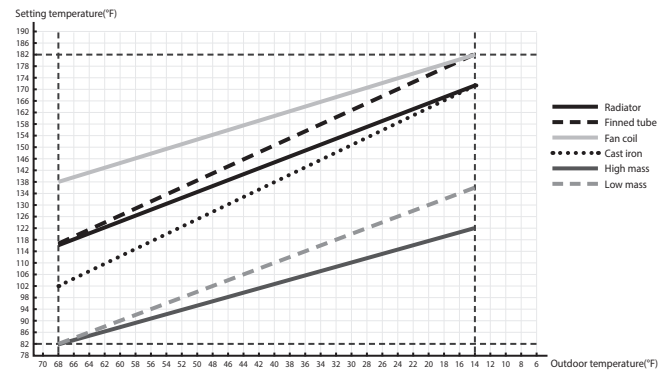

Space Heating Temperature Setting for the Outdoor Reset Control

The following tables list the default space heating temperature range by system heat load and the applicable outdoor temperature ranges.

Heat load	Minimum set-point	Maximum set-point	Out temperature Min-maximum
Finned tube heat load types	118°F(48°C)	180°F(82°C)	Minimum out temperature: 14°F(-10°C)
Fan coil	120°F(60°C)	180°F(82°C)	
Cast iron baseboard	100°F(38°C)	170°F(77°C)	
Low mass radiant	82°F(28°C)	140°F(60°C)	Maximum out temperature: 68°F(20°C)
High mass radiant	82°F(28°C)	122°F(50°C)	
Radiator	118°F(48°C)	170°F(77°C)	
Custom	User define		

## **Custom Comfort**

6 Storrs Street, Concord, NH 03301

### **For Technical Support**

877-241-1224

[www.yourcustomcomfort.com](http://www.yourcustomcomfort.com)

Ver. 1.0