

SUBMITTAL DATA SHEET



Series Name: Console Hyper Heat Series
 Model Number: CCOXHBSZ17HP/CCOXHBFM18

Console Heat Pump System

Location:	Approval:
Engineer:	Date:
Submitted to:	Construction:
Submitted by:	Unit #:
Reference:	Drawing #:



INDOOR SPECIFICATION

Indoor Air Flow (Turbo/H/M/L/Si) (CFM)	500.3 / 441.4 / 382.6 / 323.7 / 206.0
Indoor Noise Level (Turbo/H/M/L/Si) (dBA)	47/43.5/40.5/30.5/25.5
Dimensions WxDxH (inches)	31.26 x 7.87 x 24.45
Package WxDxH (inches)	34.06 x 11.02 x 28.31
Net/Gross Weight lbs.	32.85/41.89

OUTDOOR SPECIFICATION

Compressor Type	ROTARY
Compressor Model	KTM240D46UKT2
Refrigerant	R454B
Refrigerant Oil Charge(mL)	620
Refrigerant Oil	4.15/9.30
Outdoor Air Flow (Max) (CFM)	1765.8
Outdoor Noise Level (dBA)	59.0
Dimensions WxDxH (inches)	35.04 x 13.46 x 26.50
Package WxDxH (inches)	39.17 x 15.67 x 29.13
Net/Gross Weight lbs.	99.87/107.80

EFFICIENCY

Cooling		Heating	
SEER2	20	HSPF2-4	10.3
EER2	12.5	COP	2.85

COOLING PERFORMANCE (Btu/hr)

Rated Capacity	16000
Min/Max Capacity	6500~17200
Moisture Removal(L/h)	2.18
Standard Operating Range(°F/°C)	-22~122(-30~50)
Conditions:	Indoor: 80°F DB/67°F WB Outdoor: 95°F DB/75°F WB

HEATING PERFORMANCE (Btu/hr)

1. @ 47°F Rated	17000
1. @ 47°F Min/Max Capacity	6500~20000
2. @ 17°F Rated	14200
3. @ 5°F Rated: Capacity / COP	17500/1.95
3. @ 5°F Max: Capacity	17500
Standard Operating Range(°F/°C)	-22~75(-30~24)
1. Conditions:	Indoor: 70°F DB/60°F WB Outdoor: 47°F DB/43°F WB
2. Conditions:	Indoor: 70°F DB/60°F WB Outdoor: 17°F DB/15°F WB
3. Conditions:	Indoor: 70°F DB/60°F WB Outdoor: 5°F DB/5°F WB

ELECTRICAL

Power Supply	208/230V,60Hz,1Ph
System MCA	19.00
Connection Wiring	14#x4
System MOCP	20
Compressor RLA	11.7
Outdoor Fan Motor RLA	0.9
Outdoor Fan Motor W	80
Indoor Fan Motor RLA	1.0
Indoor Fan Motor W	13
System Power Input @ Cooling (W)	1280(620 ~ 1600)
System Power Input @ Heating (W)	1750(460 ~1880)
MCA: Min. circuit amps (A)	MOCP: Max. over current protection (A)
RLA: Rated load amps (A)	W: Fan motor rated output (W)

PIPING

Throttle type(Indoor)	N/A
Throttle type(Outdoor)	EXV+Throttle valve
Liquid Size	6.35mm(1/4in)
Gas Size	12.7mm(1/2in)
Max. Piping Length(ft/m)	98.40(30)
Max. Height Difference(ft/m)	65.60(20)
Max. Pre-charged Length(ft/m)	24.6(7.5)
Refrigerant Pre-charged Amount(oz/kg)	55.38(1.57)
Additional Charge (oz/ft)/(g/m)	0.16(15)
Connection Method	Flared

Indoor Unit Dimensions

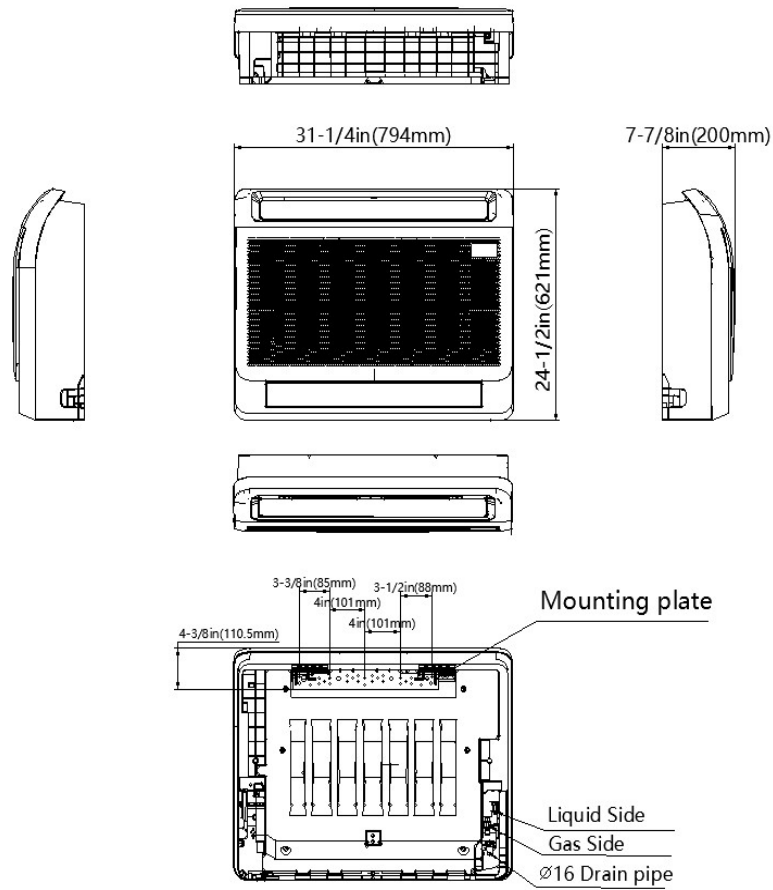

Indoor Unit Clearances

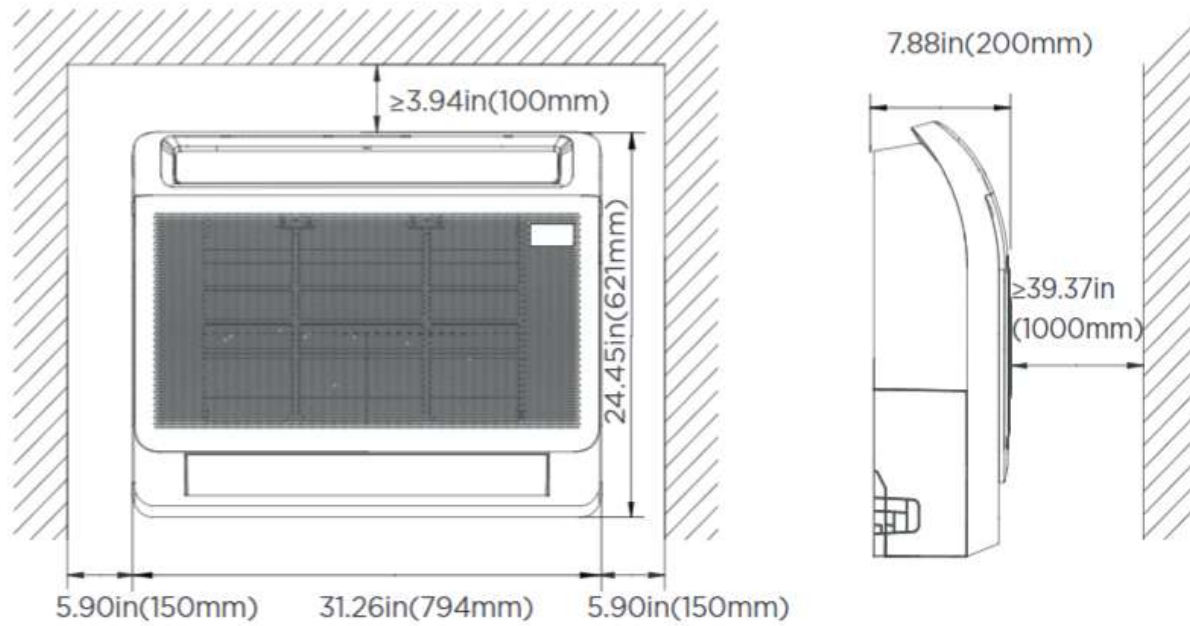

Outdoor Unit Dimensions

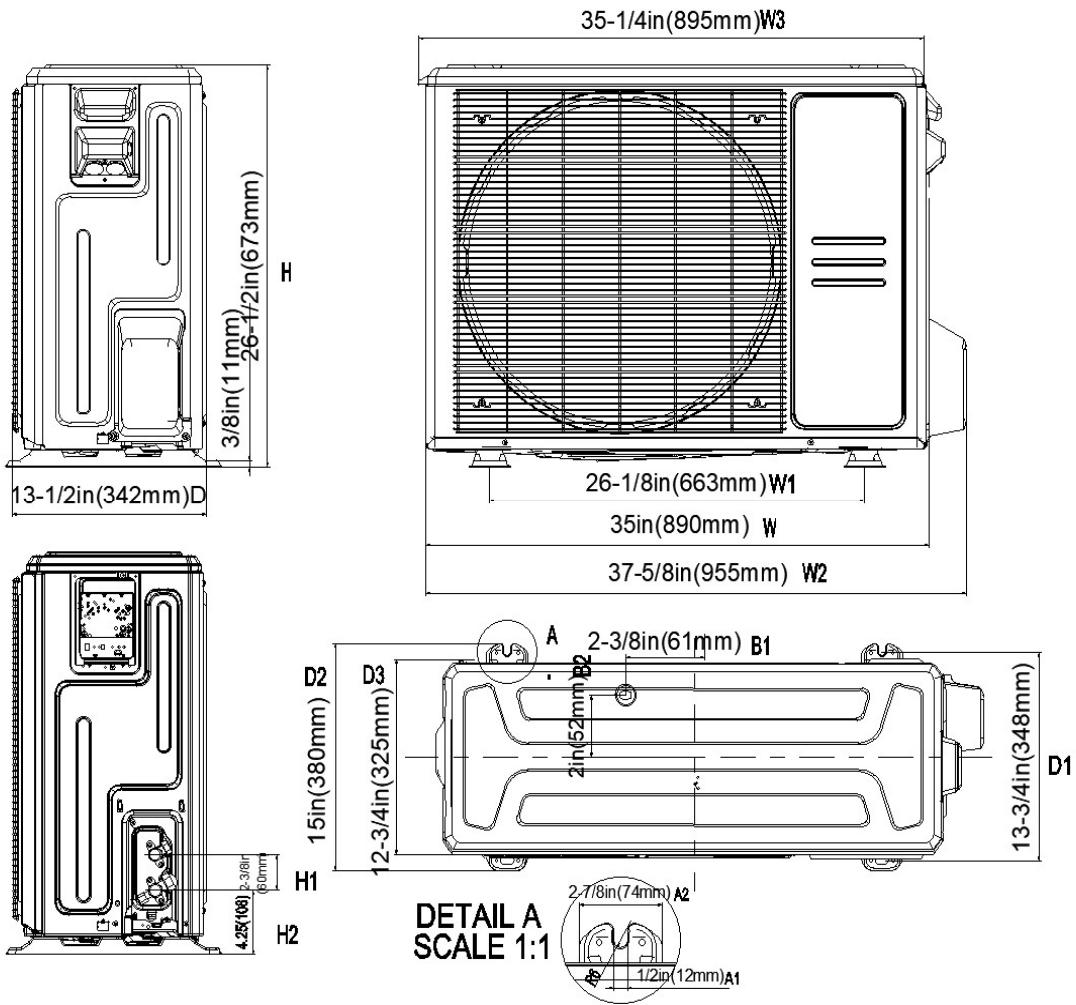

Outdoor Unit Clearances

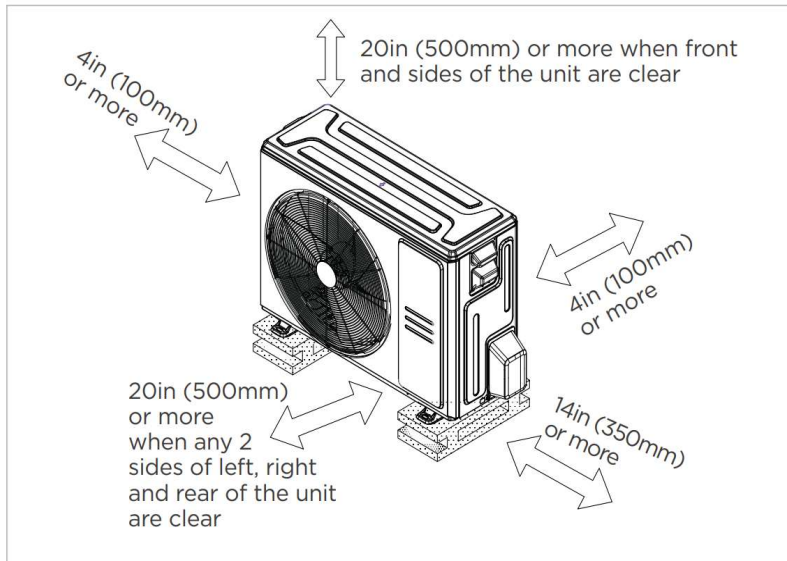

Meets all spatial requirements shown in Installation Clearance Requirements above.

Features

- Compact Design
- Dual Air Outlets
- Refrigerant leakage detection sensor
- Humidity sensor
- 1~100% fan speed setting
- WiFi capability: through WiFi dongle or wired controller with built-in WiFi
- OTA(by using WiFi dongle)
- Multiple control options available:
 - Two way communication wired controller:120N(X6)
 - Two way communication wired controller with built-in WiFi:120N(X6W)
 - Infrared wired controller: 120L
 - Wireless remote controller
 - Third-Party 24V Thermostat*

*24V interface is required.